

CONNOLLY RESIDENCE

97 Barrow St, New York, NY 10014

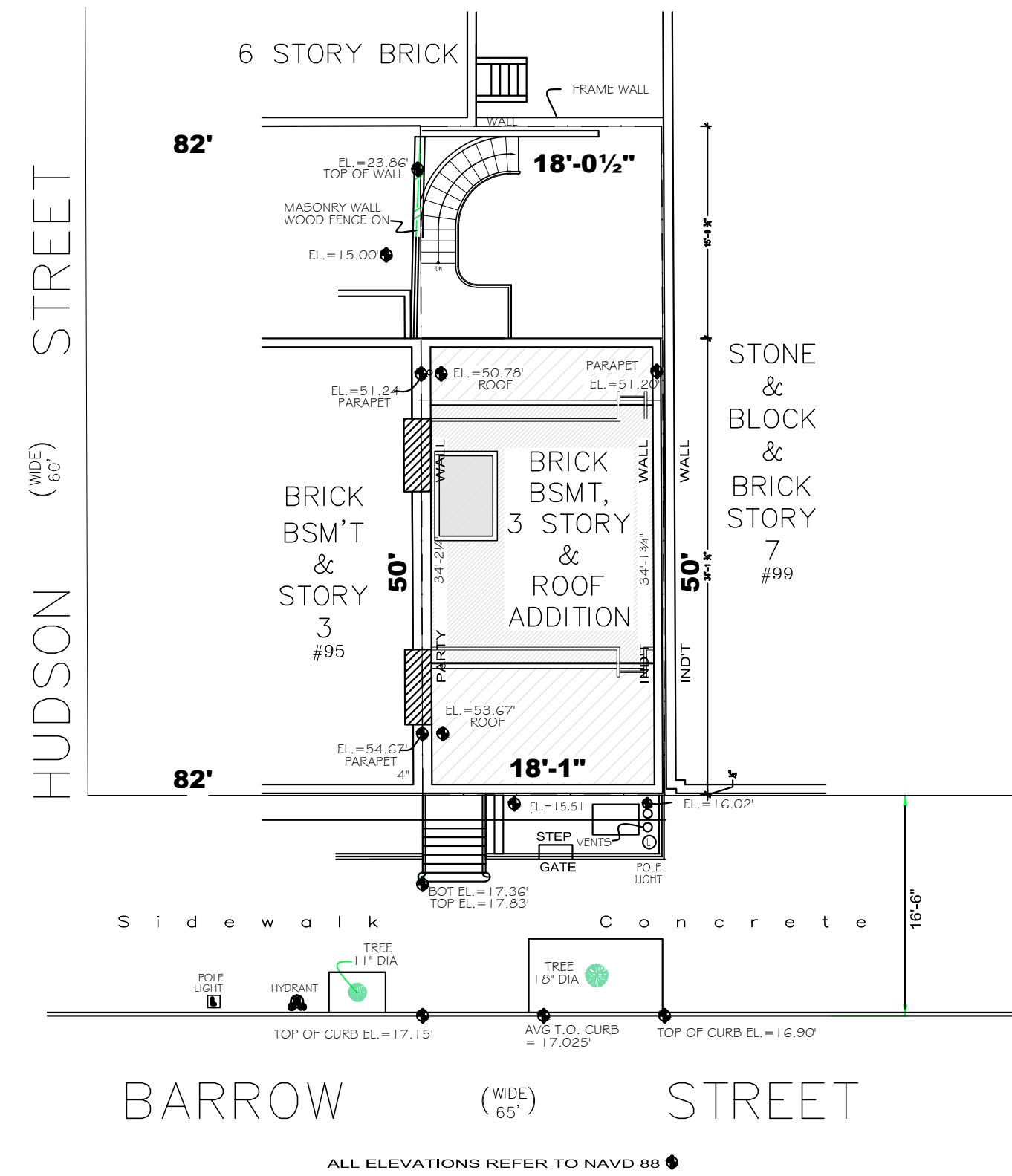

1 PLOT PLAN
SCALE: NOT TO SCALE

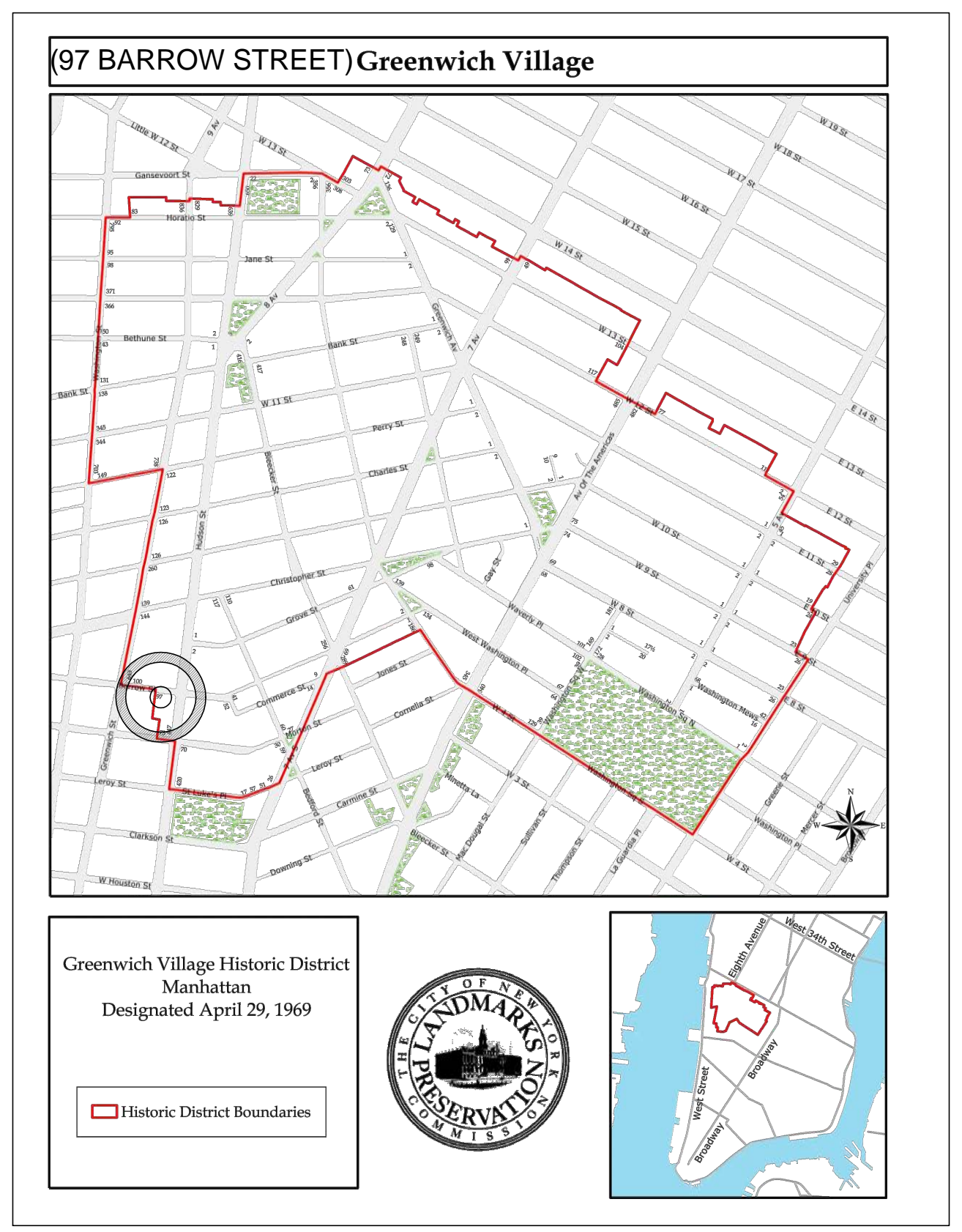

3 HISTORIC DISTRICT MAP
SCALE: NOT TO SCALE

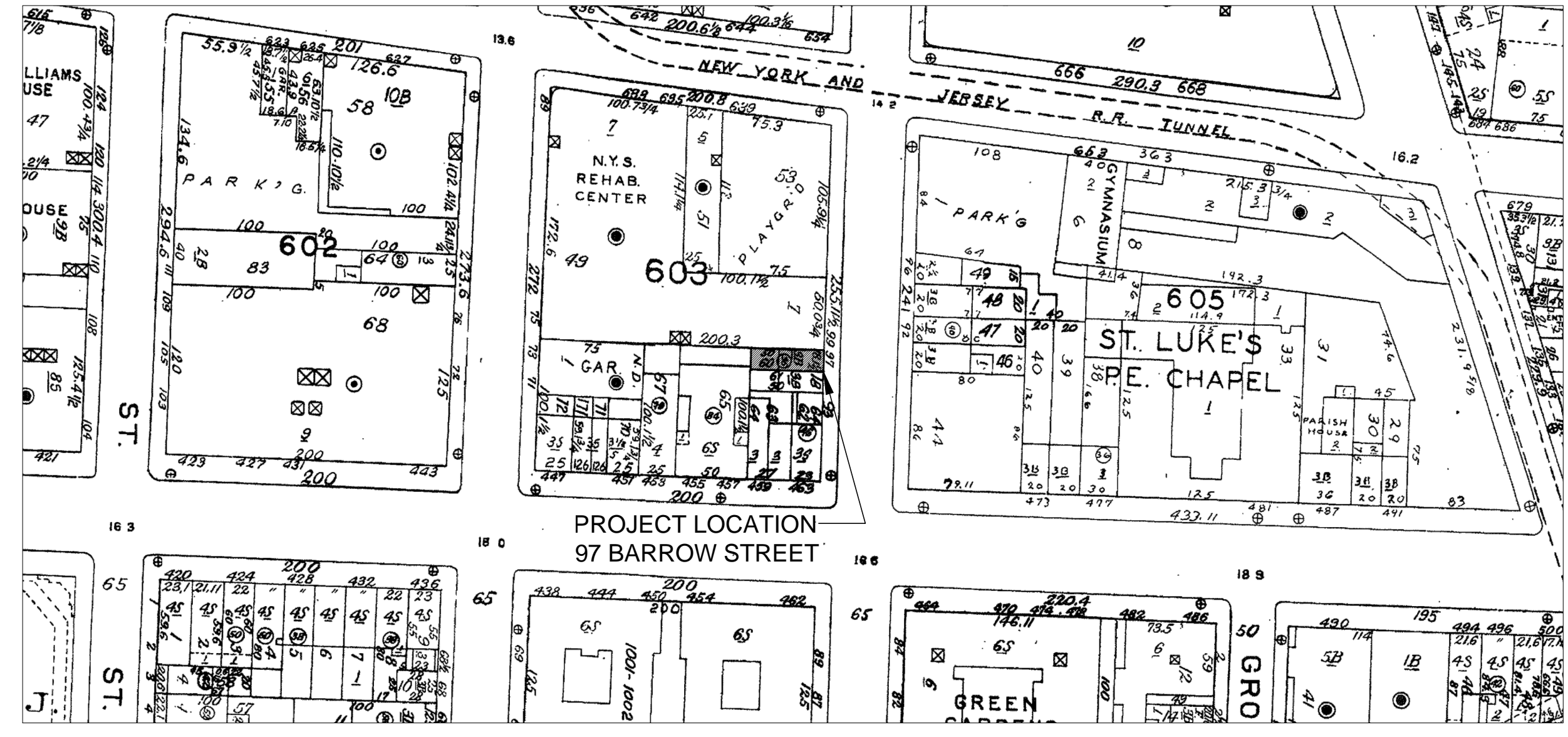

2 SANBORN MAP: PLATE 35
SCALE: NOT TO SCALE



4 HISTORIC PHOTO
SCALE: NOT TO SCALE

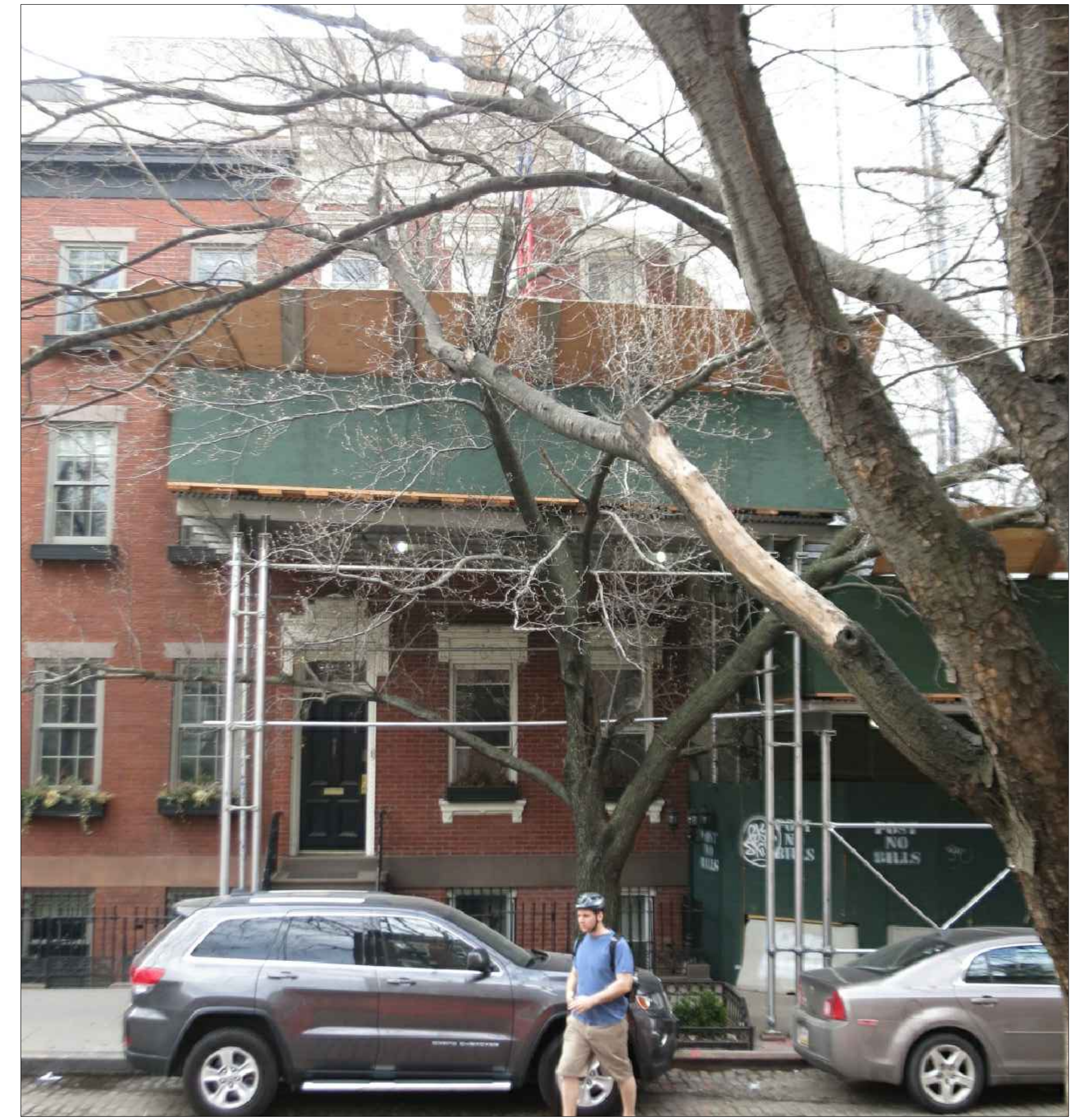

5 EXISTING FRONT FACADE
SCALE: NOT TO SCALE

LIST OF DRAWINGS:		ISSUED	02.28.17 TO LPC
G-001.00	COVER SHEET	X	
DM-100.00	EXISTING & DEMOPLANS	X	
DM-101.00	EXISTING & DEMOPLANS	X	
A-100.00	PROPOSED PLANS	X	
A-101.00	PROPOSED PLANS	X	
A-200.00	FRONT ELEVATIONS	X	
A-201.00	REAR ELEVATIONS	X	
A-300.00	EXISTING SECTION	X	
A-301.00	PROPOSED SECTION	X	
A-500	WINDOW & DOOR DETAILS	X	
LPC-1	LINE OF SIGHT DIAGRAM	X	
LPC-2	ROOF ADDITION	X	
LPC-3	FACADE PHOTOS	X	
ZD1	ZONING DIAGRAM	X	

BAXTINGUI
Architects PC

20 Vesey Street Suite 900
New York, New York 10007
T. 212.233.6740 F. 212.962.5126
© 2011

28 FEB 2017
TO LPC

**Connolly
Residence**
97 BARROW ST
NEW YORK, NY

LPC-001
COVER PAGE
1 OF 12

LEGEND	
	EXISTING WALL
	PROPOSED WALL
	SOFFIT
	WALL TAG
	EXHAUST FAN
	SMOKE/CARBON MONOXIDE DETECTOR

NOTES	
1.	EXHAUST DUCTS FOR CLOTHES DRYERS SHALL TERMINATE ON THE OUTSIDE OF THE BUILDING AND SHALL BE EQUIPPED WITH A BACKDRAFT DAMPER. SCREENS SHALL NOT BE INSTALLED AT THE DUCT TERMINATION
2.	VERTICAL DRYER DUCT SHALL BE PROVIDED WITH A CLEANOUT FOR CLEANING INTERIOR OF THE DUCT
3.	DRYER DUCT SHALL BE A MINIMUM NOMINAL SIZE OF 4" IN DIAMETER AND THE MAXIMUM LENGTH SHALL NOT EXCEED 25'-0" FROM DRYER TO OUTLET TERMINAL
4.	THE MAXIMUM LENGTH OF THE DUCT SHALL BE REDUCED BY 2'-6" FOR EACH 45° BEND AND 5'-0" FOR EACH 90° BEND

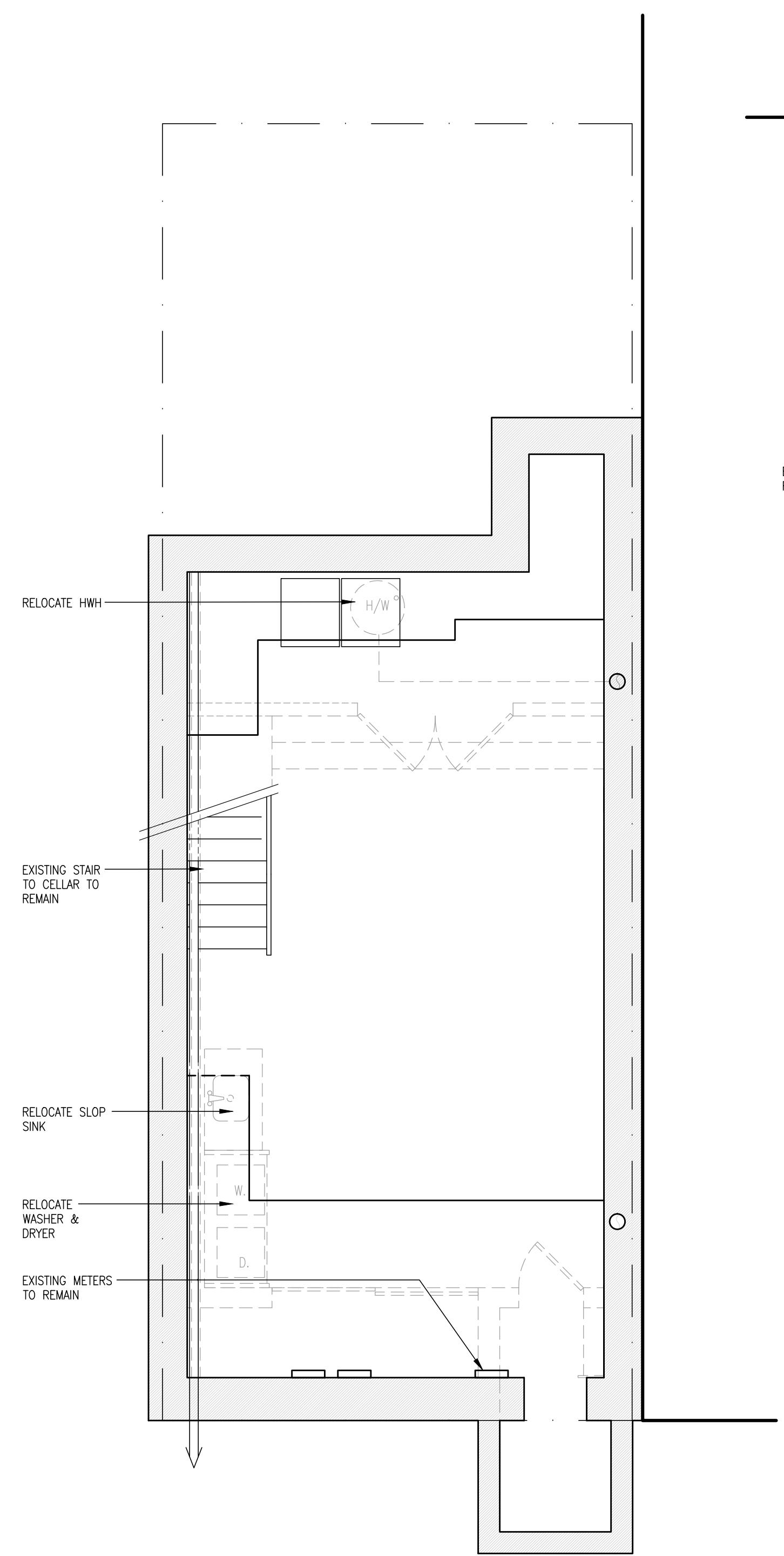

CELLAR DEMOLITION PLAN
SCALE: 1/4" = 1'-0"

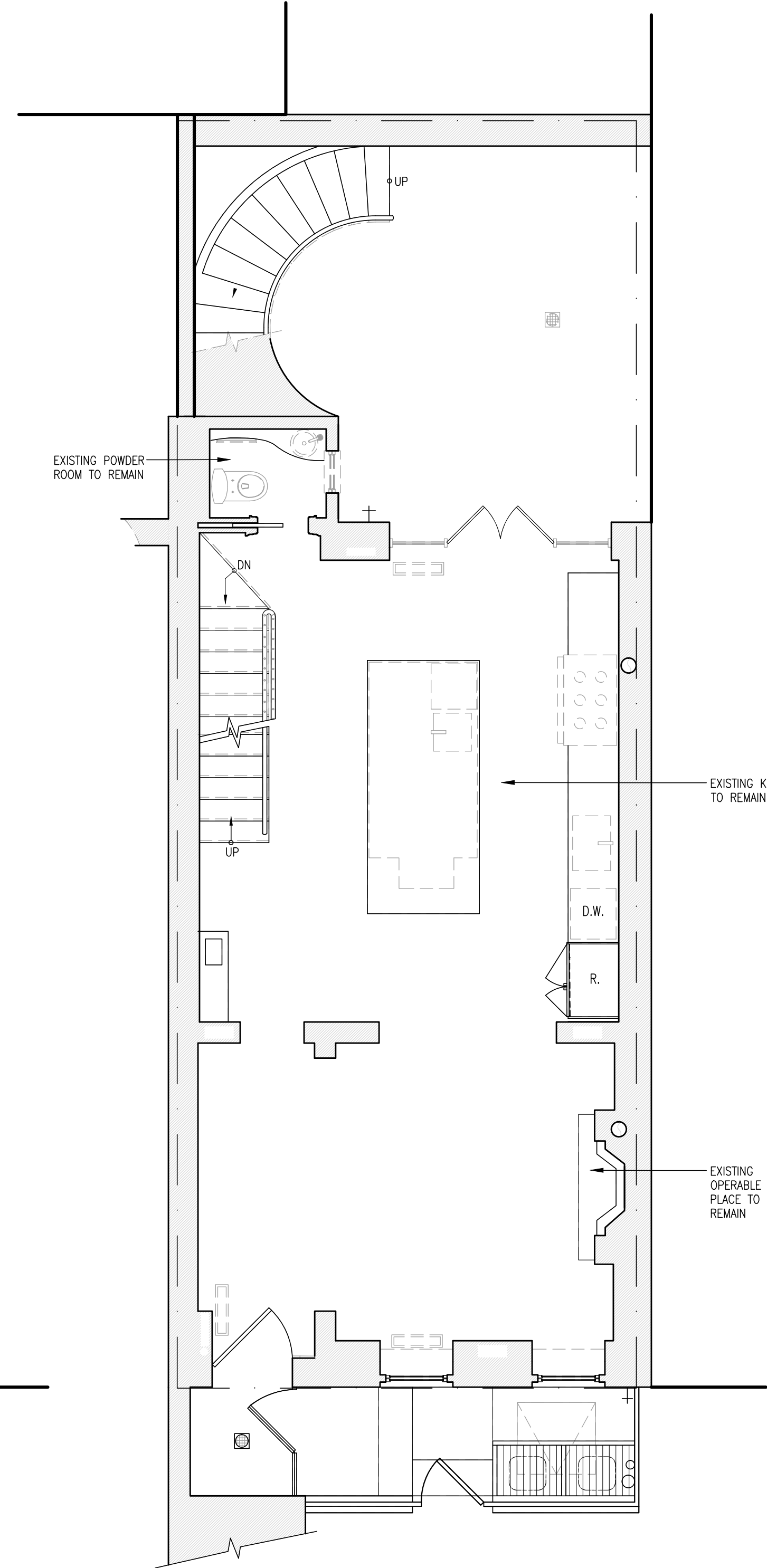

BASEMENT DEMOLITION PLAN
SCALE: 1/4" = 1'-0"

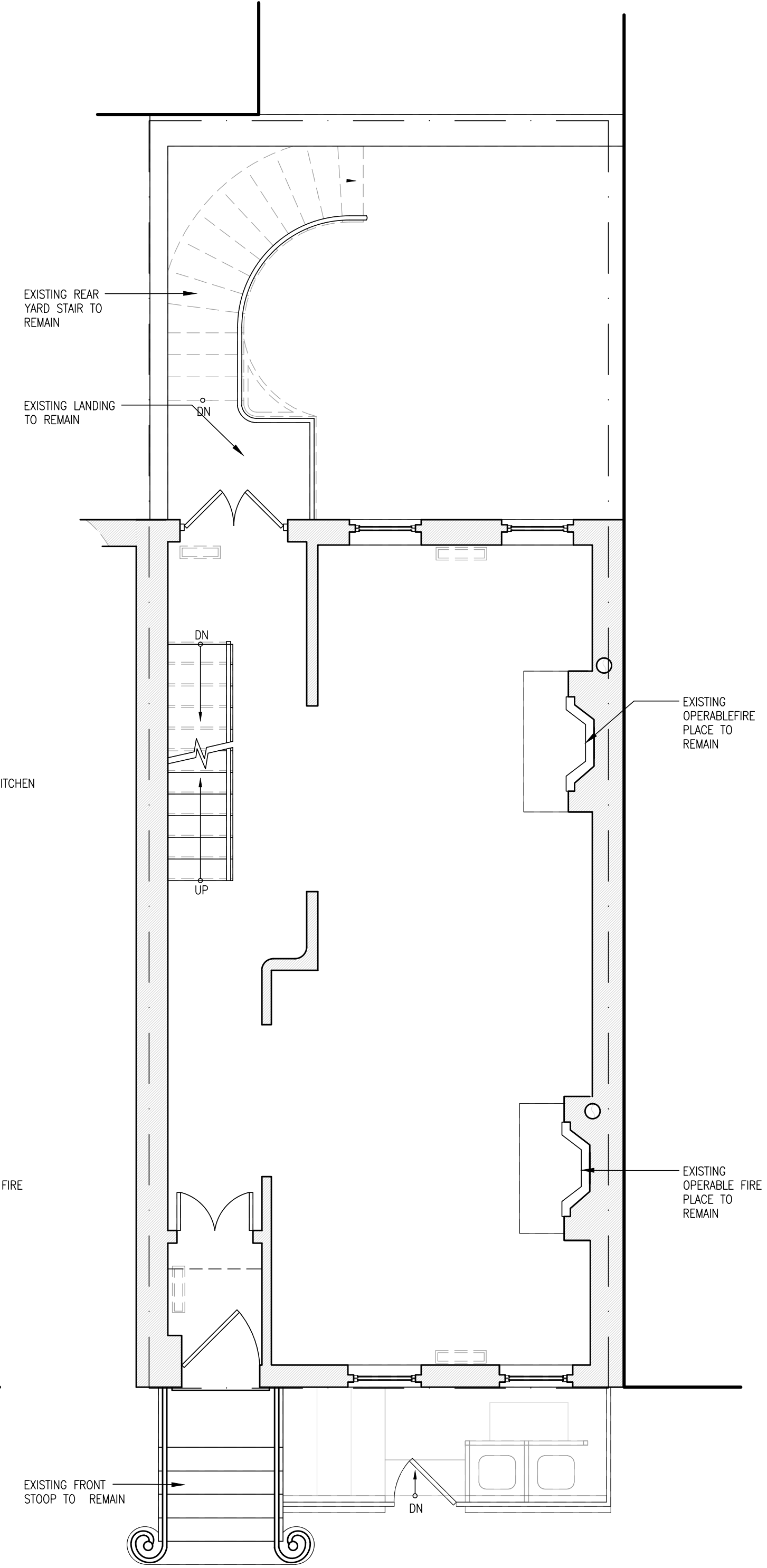







1ST FLOOR DEMOLITION PLAN
SCALE: 1/4" = 1'-0"

28 FEB 2017
TO LPC

Connolly Residence
97 BARROW ST
NEW YORK, NY

DM-100.00

DEMOLITION PLANS
2 OF 12

LEGEND	
	EXISTING WALL
	PROPOSED WALL
	SOFFIT
	WALL TAG
	EXHAUST FAN
	SMOKE/CARBON MONOXIDE DETECTOR

NOTES	
1.	EXHAUST DUCTS FOR CLOTHES DRYERS SHALL TERMINATE ON THE OUTSIDE OF THE BUILDING AND SHALL BE EQUIPPED WITH A BACKDRAFT DAMPER. SCREENS SHALL NOT BE INSTALLED AT THE DUCT TERMINATION
2.	VERTICAL DRYER DUCT SHALL BE PROVIDED WITH A CLEANOUT FOR CLEANING INTERIOR OF THE DUCT
3.	DRYER DUCT SHALL BE A MINIMUM NOMINAL SIZE OF 4" IN DIAMETER AND THE MAXIMUM LENGTH SHALL NOT EXCEED 25'-0" FROM DRYER TO OUTLET TERMINAL
4.	THE MAXIMUM LENGTH OF THE DUCT SHALL BE REDUCED BY 2'-6" FOR EACH 45° BEND AND 5'-0" FOR EACH 90° BEND

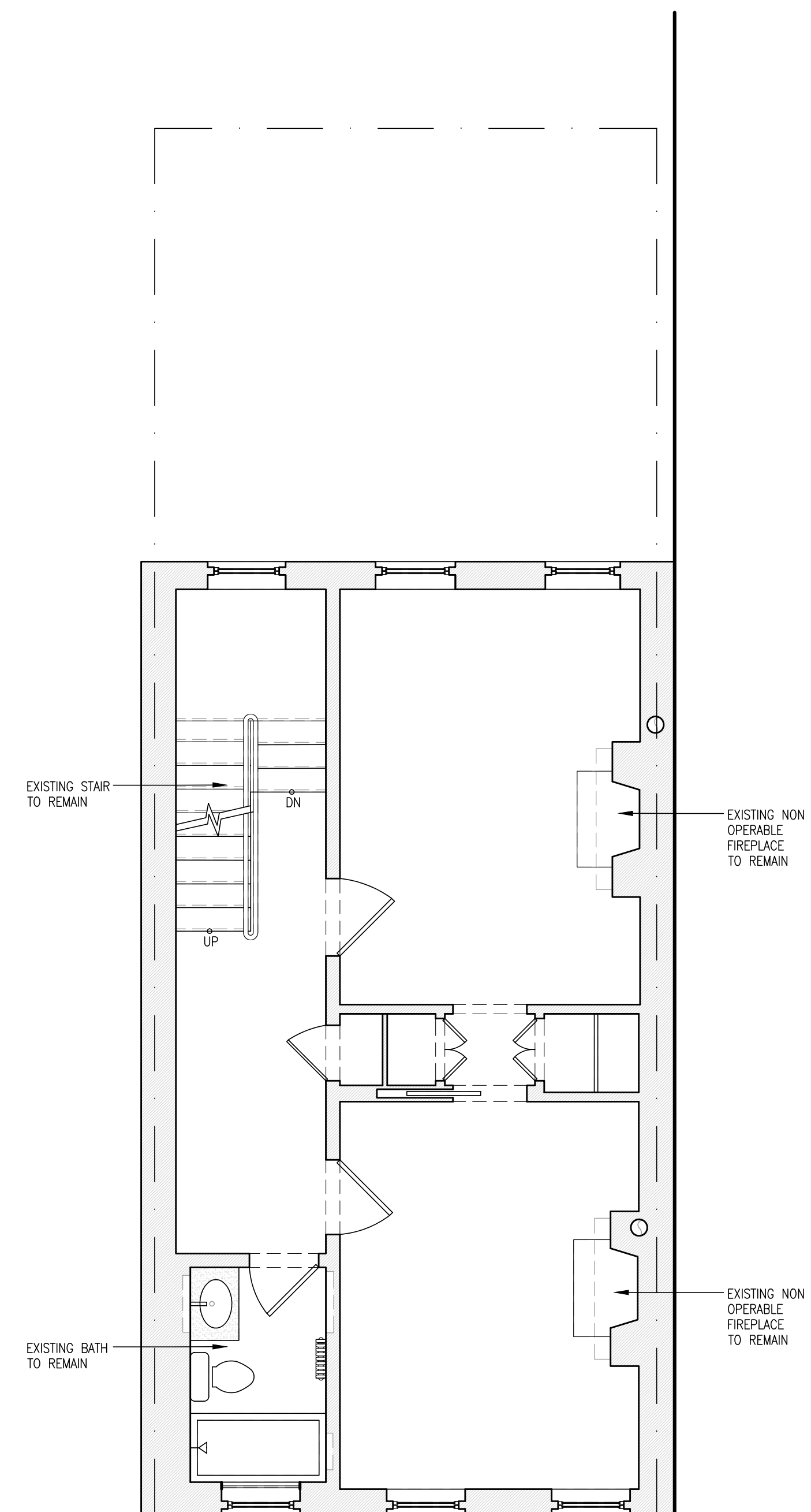

2ND FLOOR DEMOLITION PLAN
SCALE: 1/4" = 1'-0"

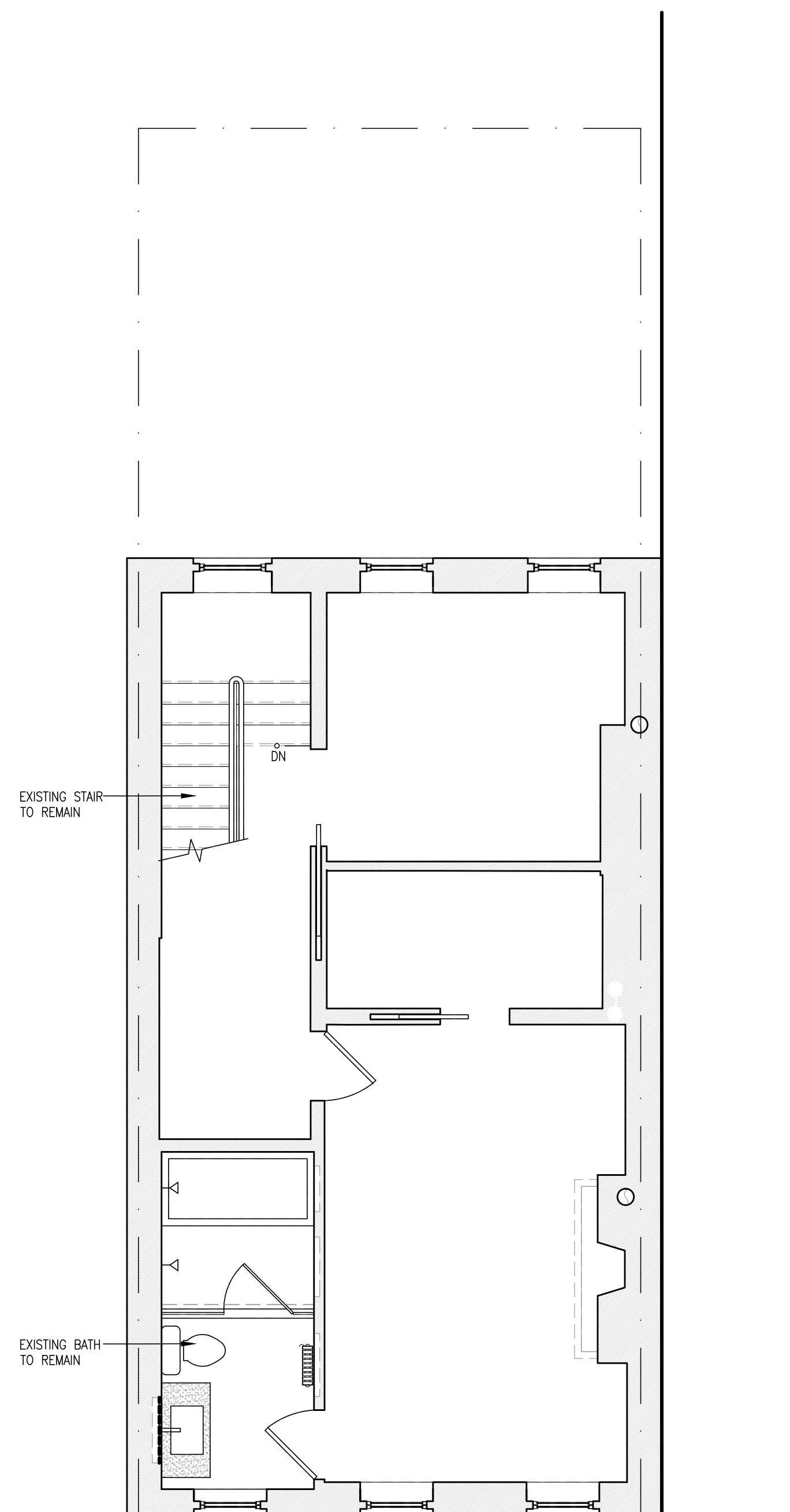

3RD FLOOR DEMOLITION PLAN
SCALE: 1/4" = 1'-0"

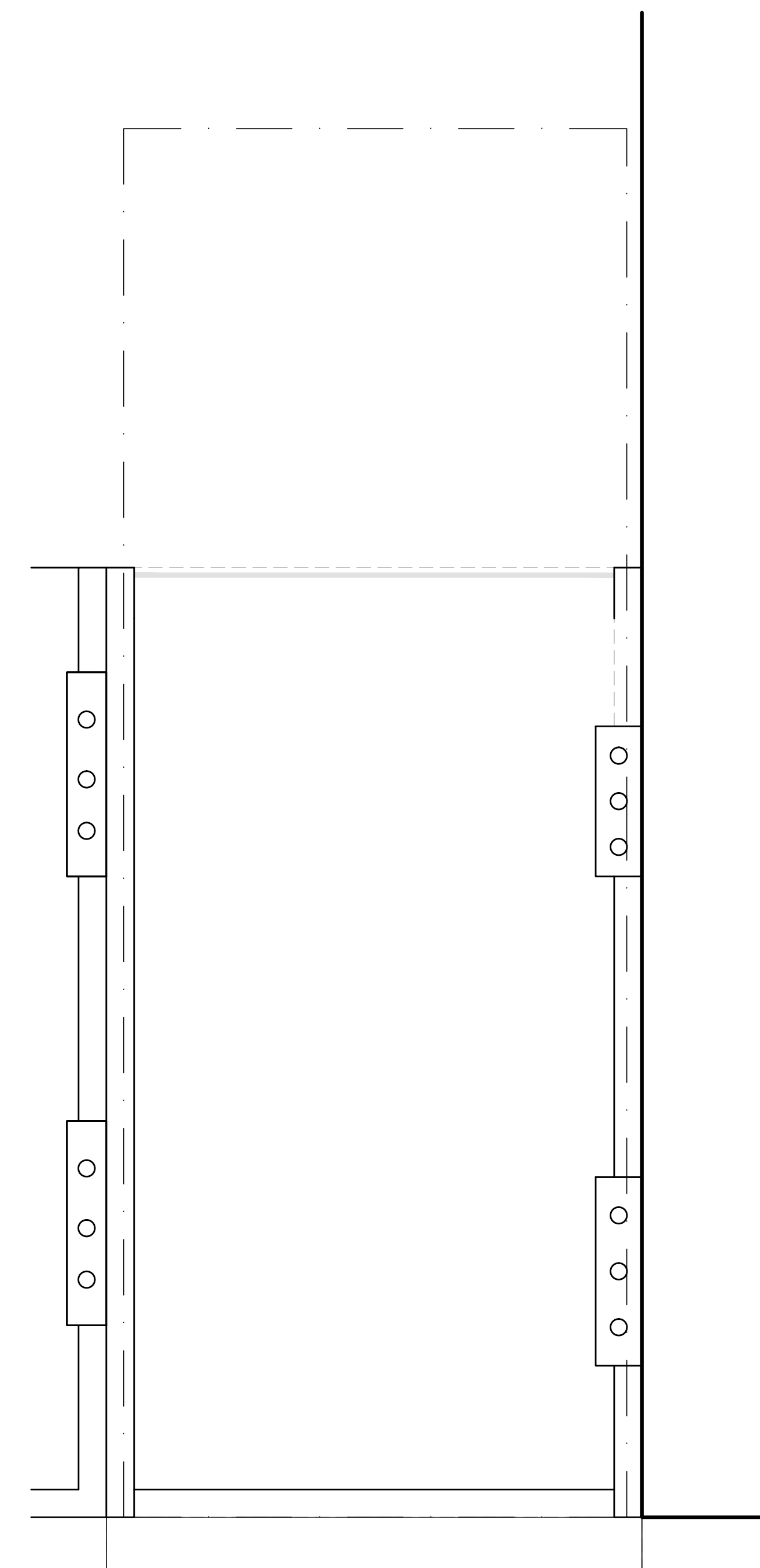

ROOF DEMOLITION PLAN
SCALE: 1/4" = 1'-0"

28 FEB 2017
TO LPC

**Connolly
Residence**

97 BARROW ST
NEW YORK, NY

DM-101.00

DEMOLITION PLANS

3 OF 12

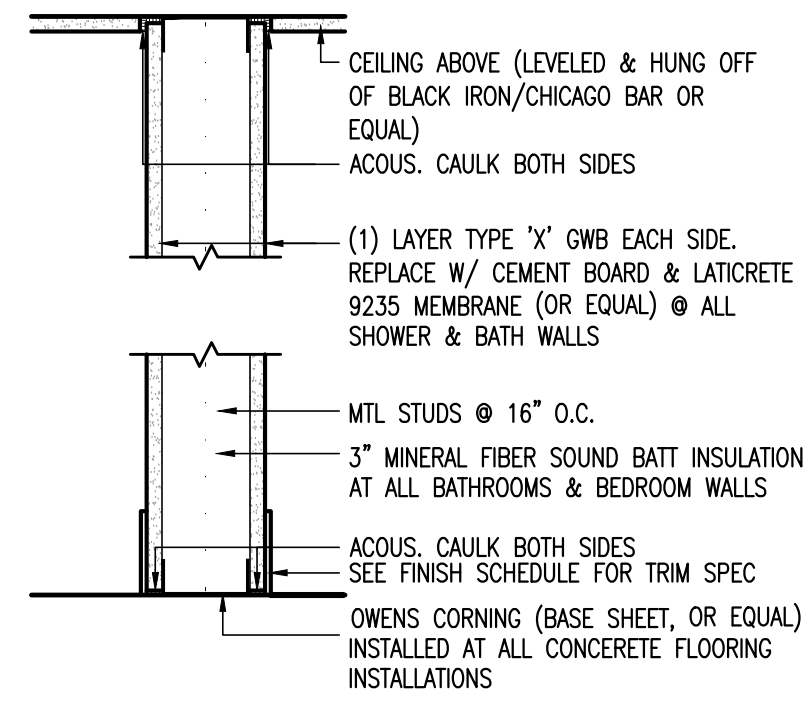

1 1 H.R. PARTITION
N.T.S.
UL # = DESIGN U425

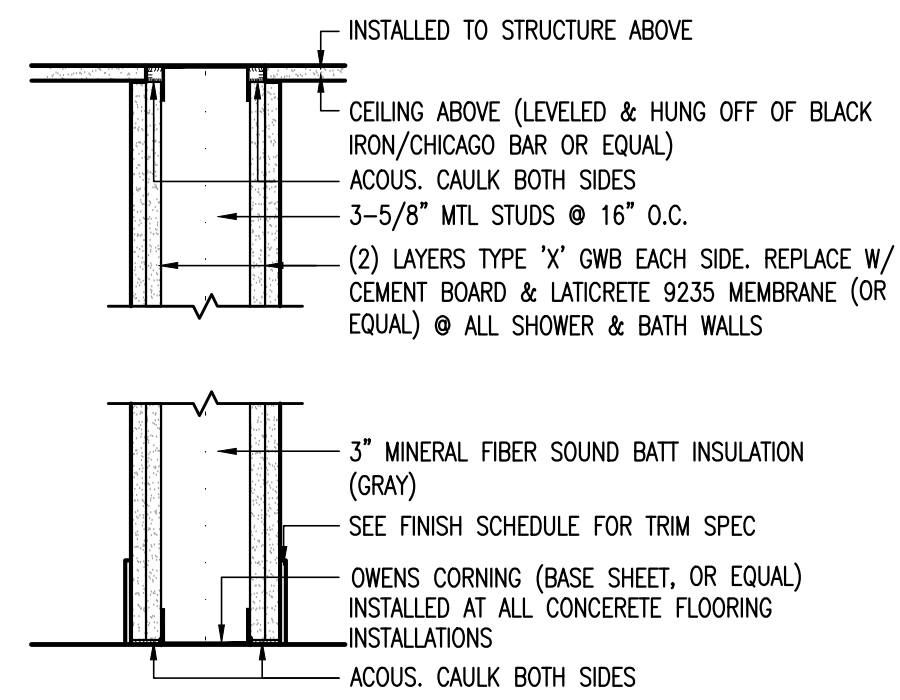

2 2 H.R. RATED PARTITION
N.T.S.
UL # = DESIGN U425

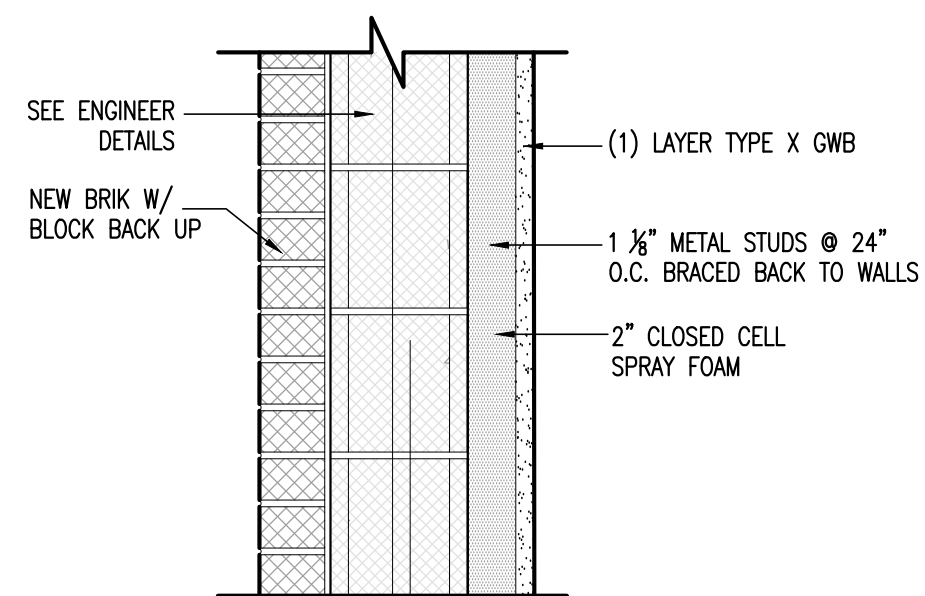

3 NEW EXTERIOR WALL DETAIL
SCALE: NTS
UL # = DESIGN U425

LEGEND

- EXISTING WALL
- PROPOSED WALL
- SOFFIT
- WALL TAG
- EXHAUST FAN
- SMOKE/CARBON MONOXIDE DETECTOR

NOTES

- EXHAUST DUCTS FOR CLOTHES DRYERS SHALL TERMINATE ON THE OUTSIDE OF THE BUILDING AND SHALL BE EQUIPPED WITH A BACKDRAFT DAMPER. SCREENS SHALL NOT BE INSTALLED AT THE DUCT TERMINATION
- VERTICAL DRYER DUCT SHALL BE PROVIDED WITH A CLEANOUT FOR CLEANING INTERIOR OF THE DUCT
- DRYER DUCT SHALL BE A MINIMUM NOMINAL SIZE OF 4" IN DIAMETER AND THE MAXIMUM LENGTH SHALL NOT EXCEED 25'-0" FROM DRYER TO OUTLET TERMINAL
- THE MAXIMUM LENGTH OF THE DUCT SHALL BE REDUCED BY 2'-6" FOR EACH 45° BEND AND 5'-0" FOR EACH 90° BEND

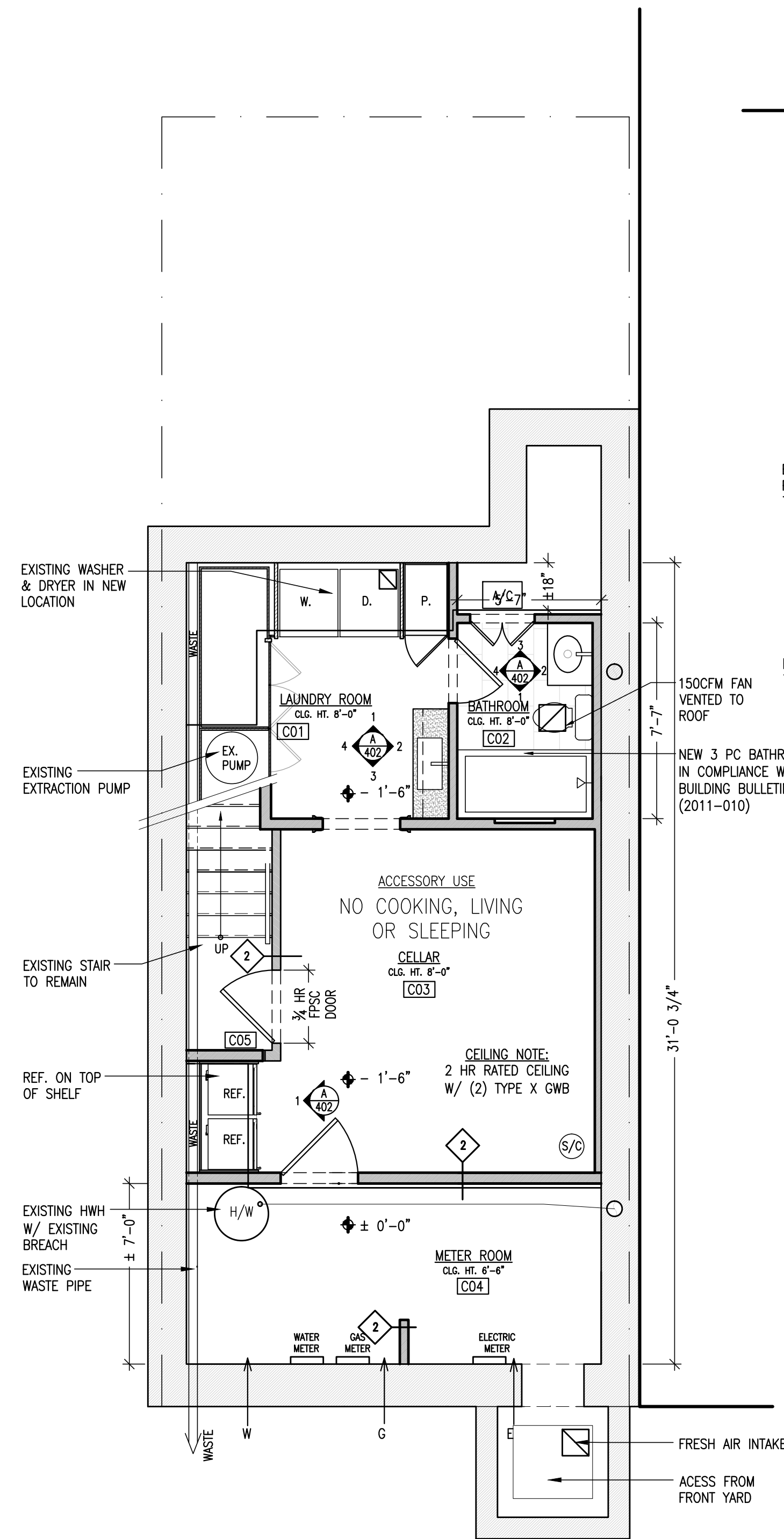

CELLAR FLOOR PLAN
SCALE: 1/4" = 1'-0"

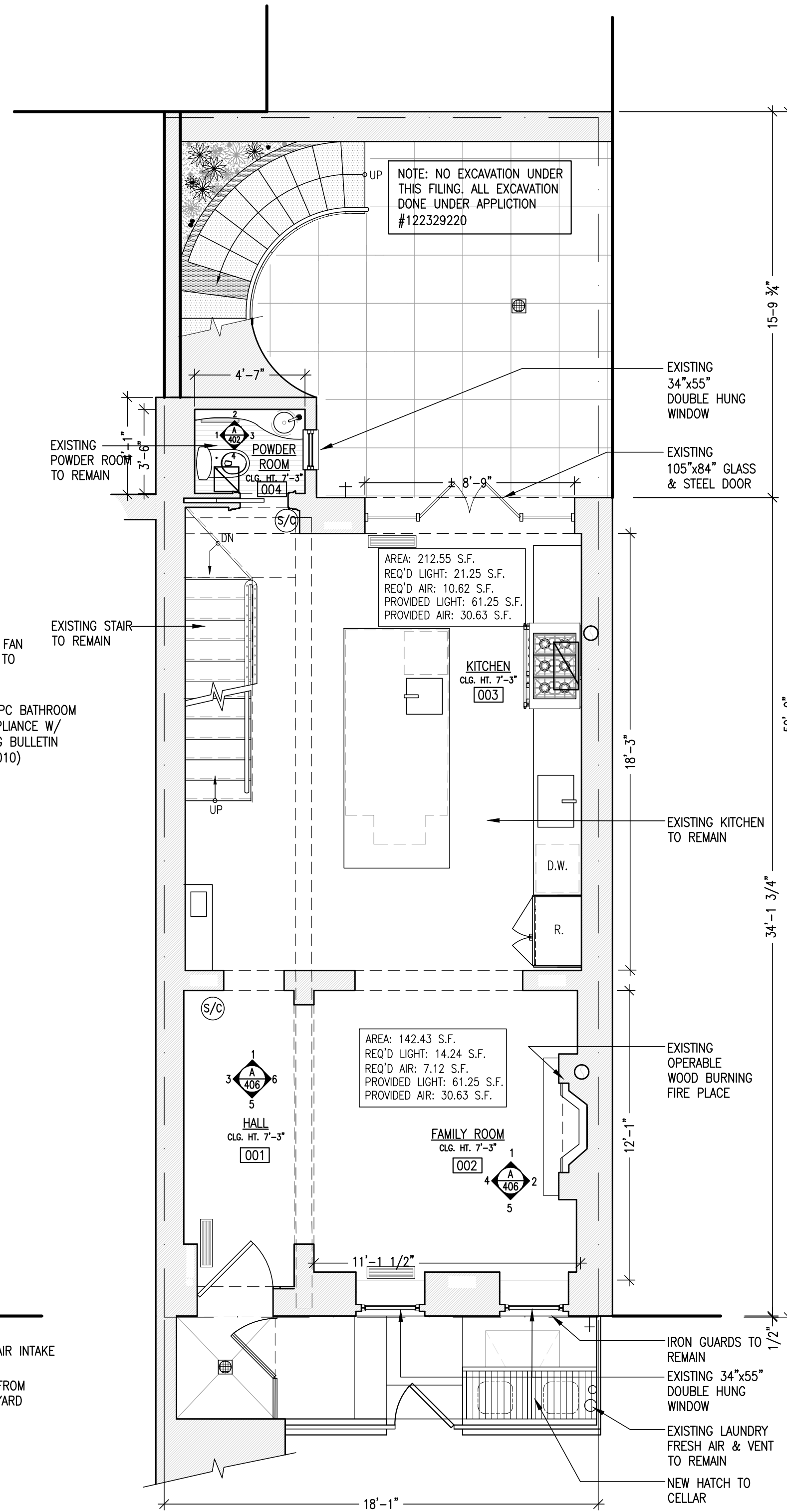

BASEMENT FLOOR PLAN
SCALE: 1/4" = 1'-0"

ALL WORK THIS FLOOR APPROVED UNDER APPLICATION'S #122329220 & #122926227

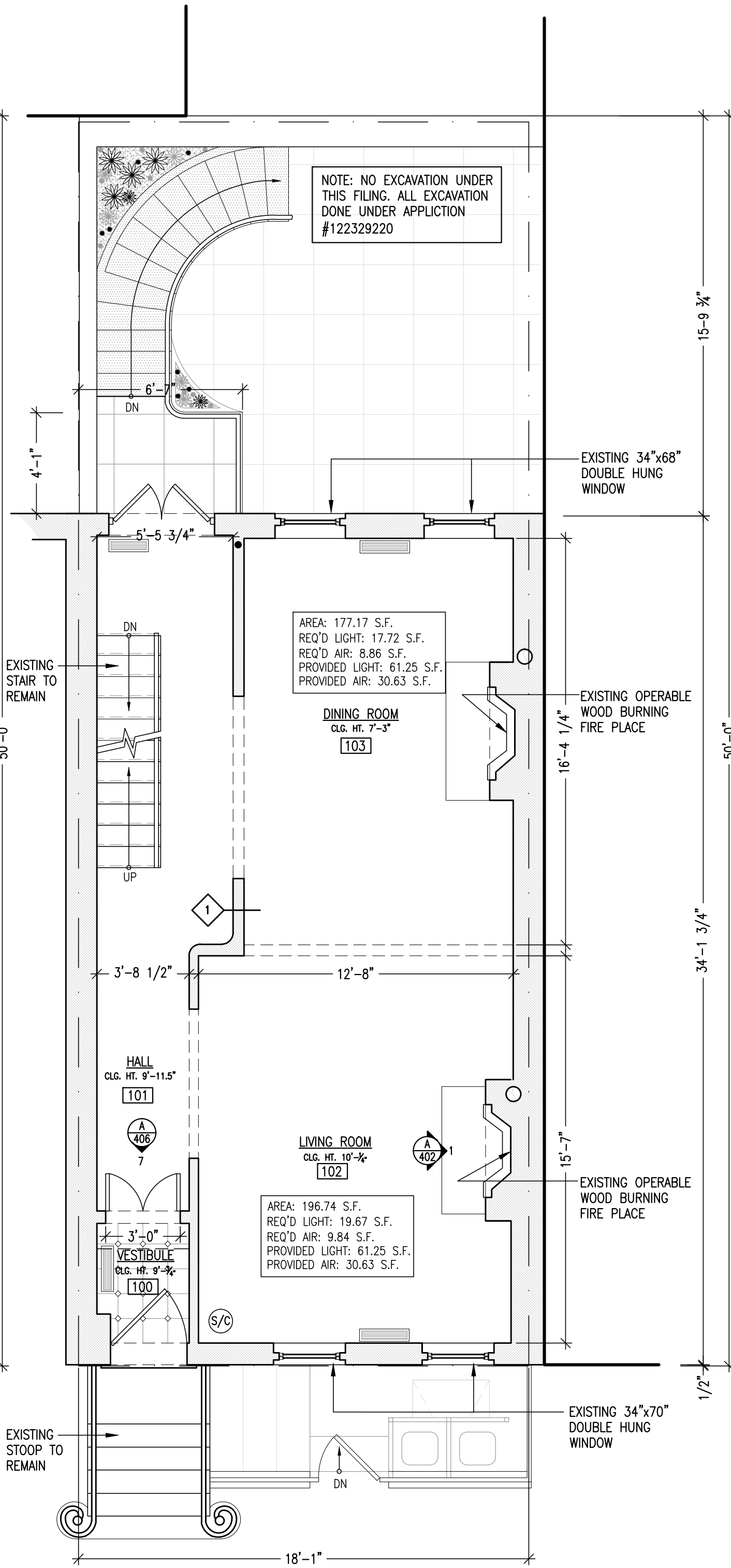

FIRST FLOOR PLAN
SCALE: 1/4" = 1'-0"

ALL WORK THIS FLOOR APPROVED UNDER APPLICATION'S #122329220 & #122926227

28 FEB 2017
TO LPC

LEGEND	
	EXISTING WALL
	PROPOSED WALL
	SOFFIT
	WALL TAG
	EXHAUST FAN
	SMOKE/CARBON MONOXIDE DETECTOR

- NOTES**
- EXHAUST DUCTS FOR CLOTHES DRYERS SHALL TERMINATE ON THE OUTSIDE OF THE BUILDING AND SHALL BE EQUIPPED WITH A BACKDRAFT DAMPER. SCREENS SHALL NOT BE INSTALLED AT THE DUCT TERMINATION
 - VERTICAL DRYER DUCT SHALL BE PROVIDED WITH A CLEANOUT FOR CLEANING INTERIOR OF THE DUCT
 - DRYER DUCT SHALL BE A MINIMUM NOMINAL SIZE OF 4" IN DIAMETER AND THE MAXIMUM LENGTH SHALL NOT EXCEED 25'-0" FROM DRYER TO OUTLET TERMINAL
 - THE MAXIMUM LENGTH OF THE DUCT SHALL BE REDUCED BY 2'-6" FOR EACH 45° BEND AND 5'-0" FOR EACH 90° BEND

BAXTINGUI
Architects PC

20 Vesey Street Suite 900
New York, New York 10007
T. 212.233.6740 F. 212.962.5126
© 2011

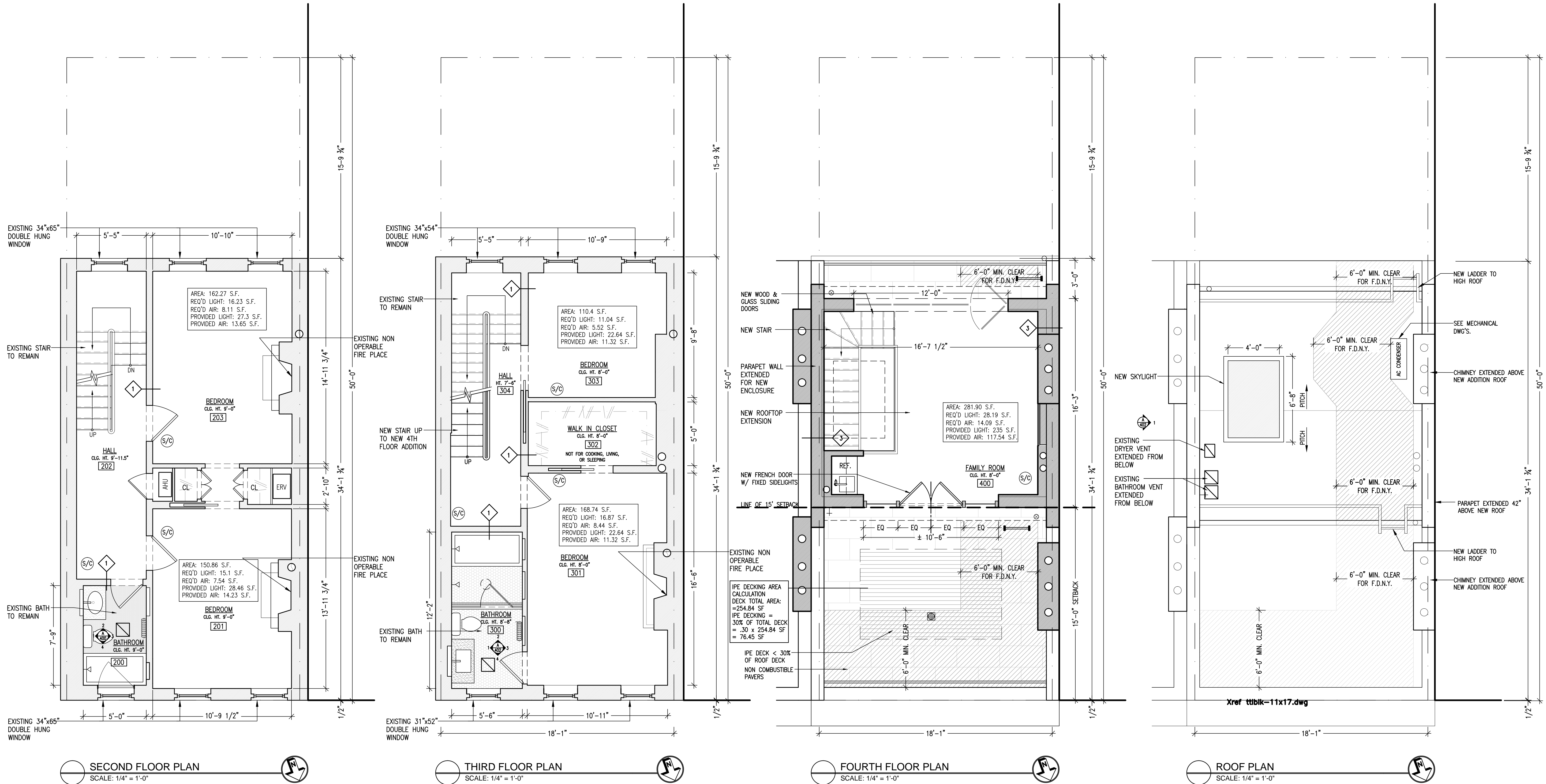

28 FEB 2017
TO LPC

Connolly Residence
97 BARROW ST
NEW YORK, NY

A-101.00
PROPOSED PLANS
5 OF 12

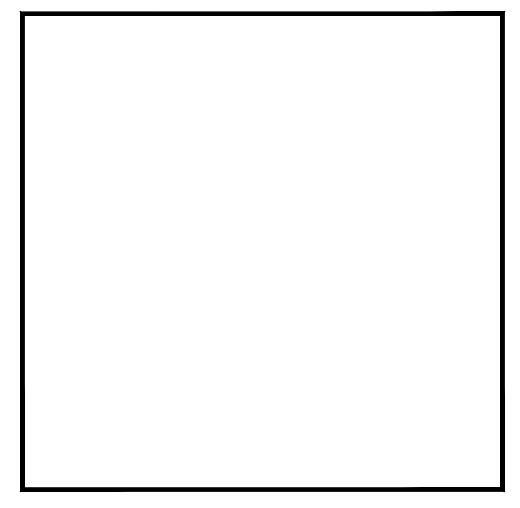
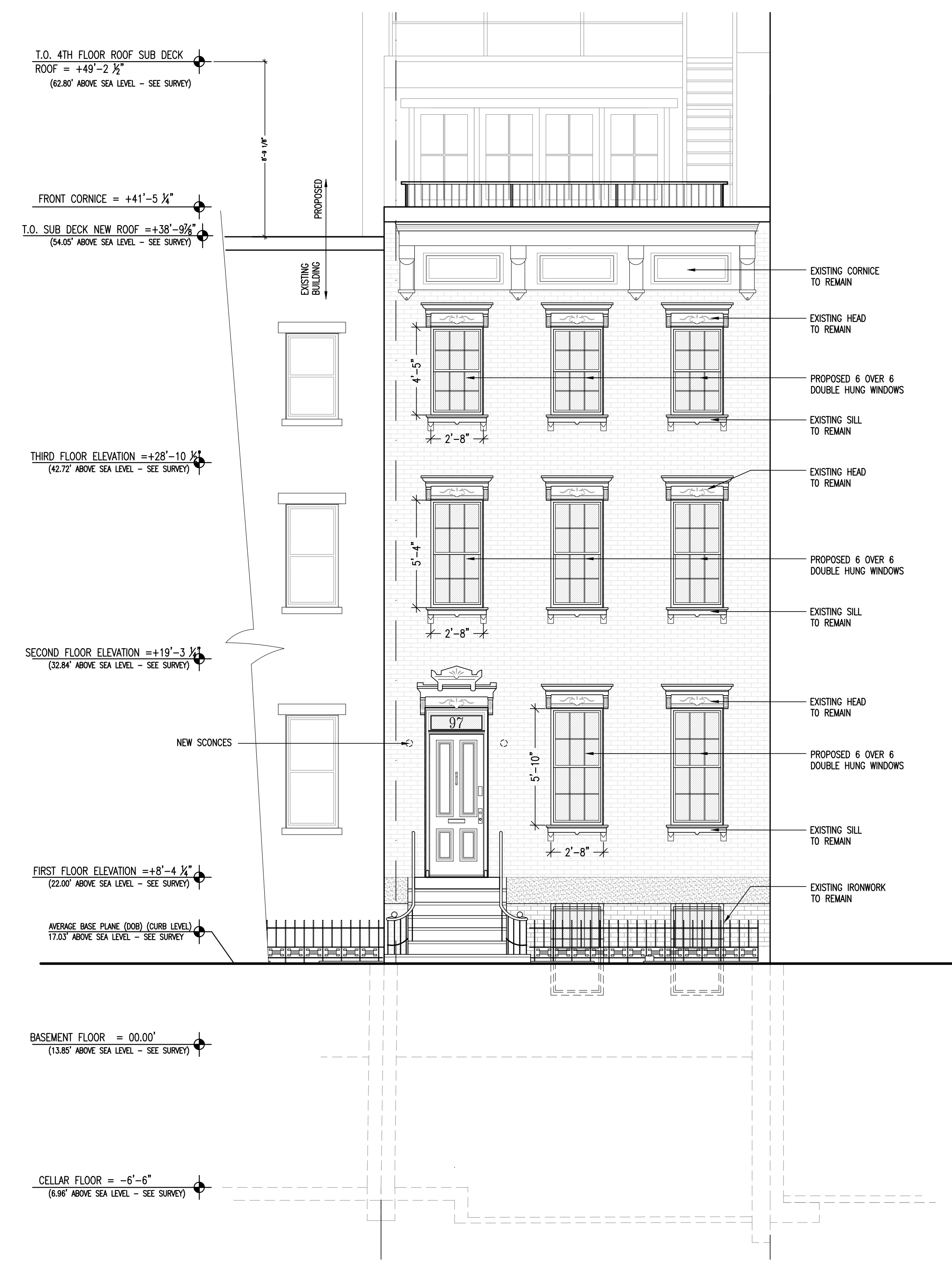
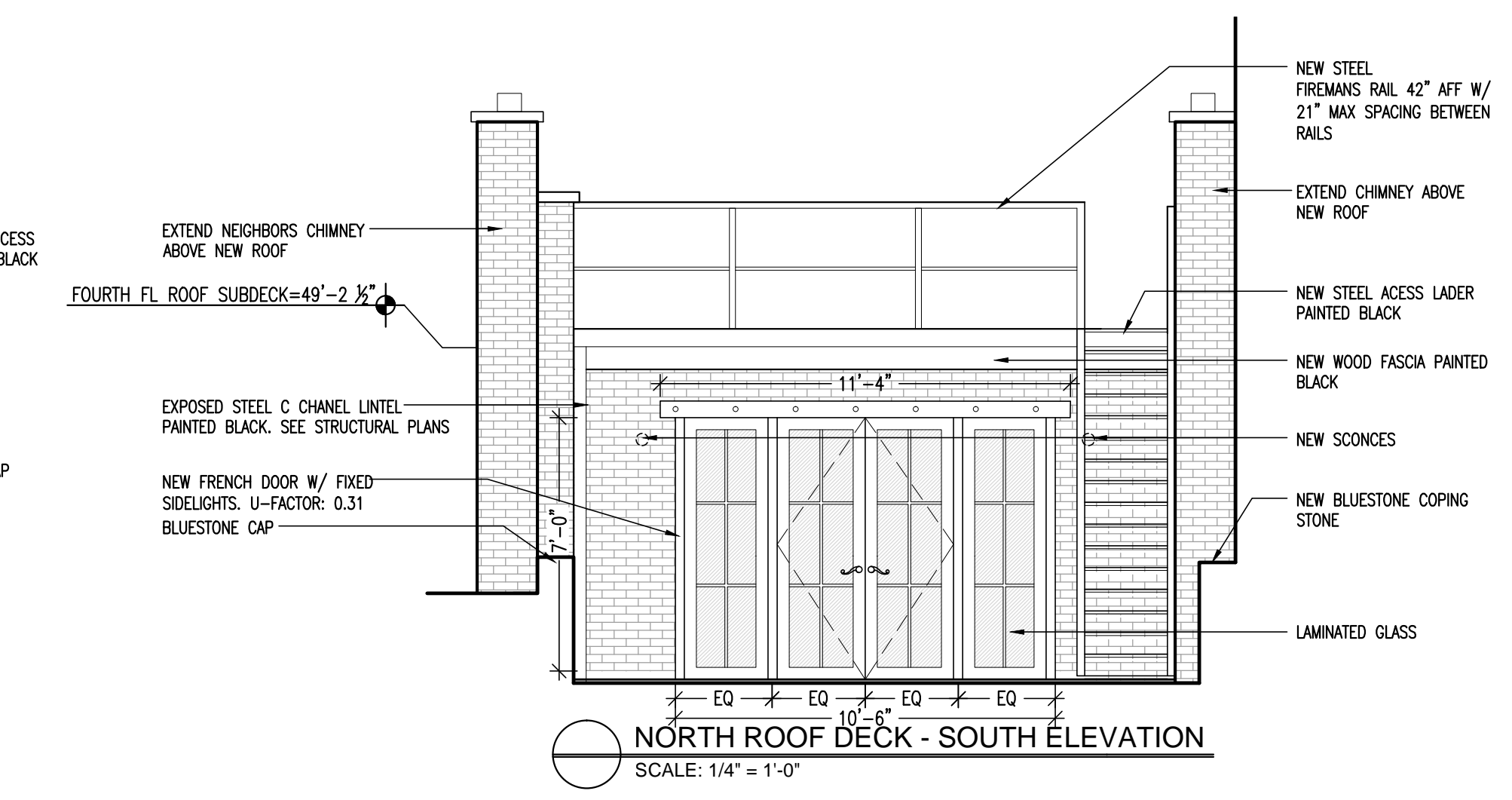
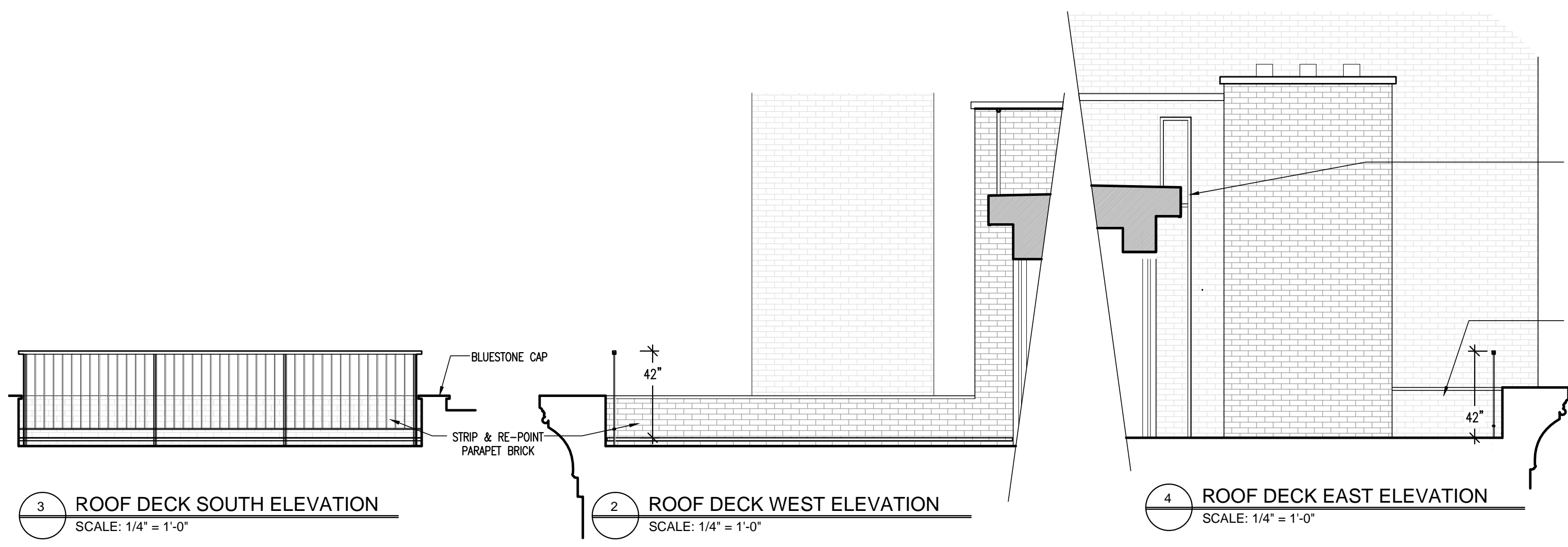

BAXT INGUI
Architects PC

20 Vesey Street Suite 900
New York, New York 10007
T. 212.233.6740 F. 212.962.5126
© 2011

28 FEB 2017
TO LPC

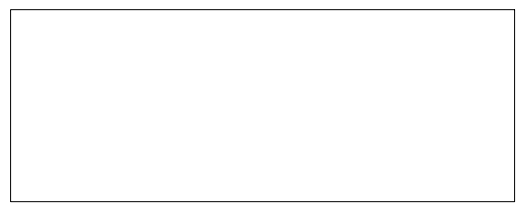

**Connolly
Residence**

97 BARROW ST
NEW YORK, NY

A-200.00

EXISTING & PROPOSED
FRONT ELEVATIONS

6 OF 12

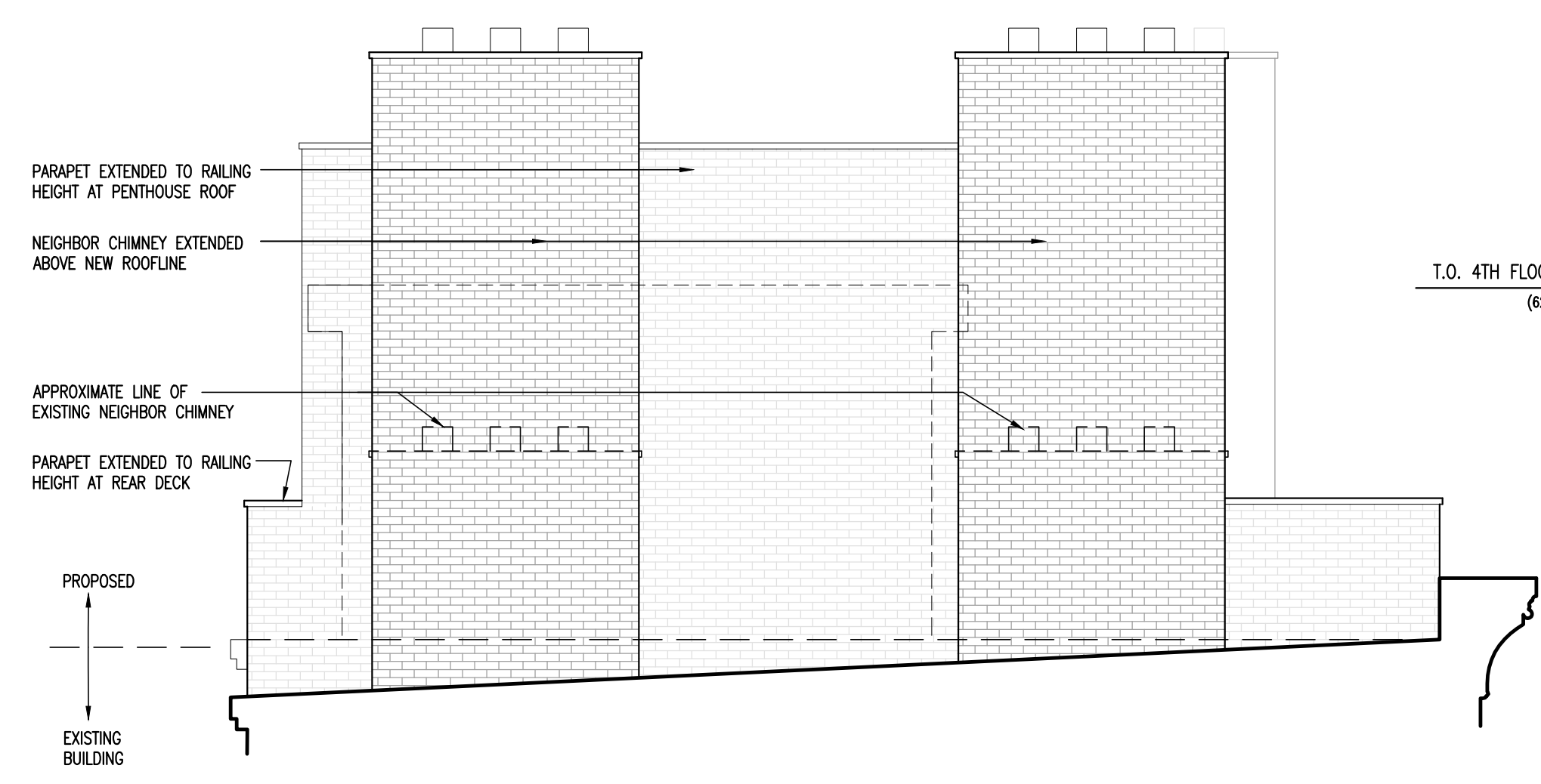

3 ADDITION - EAST ELEVATION
SCALE: 1/4" = 1'-0"

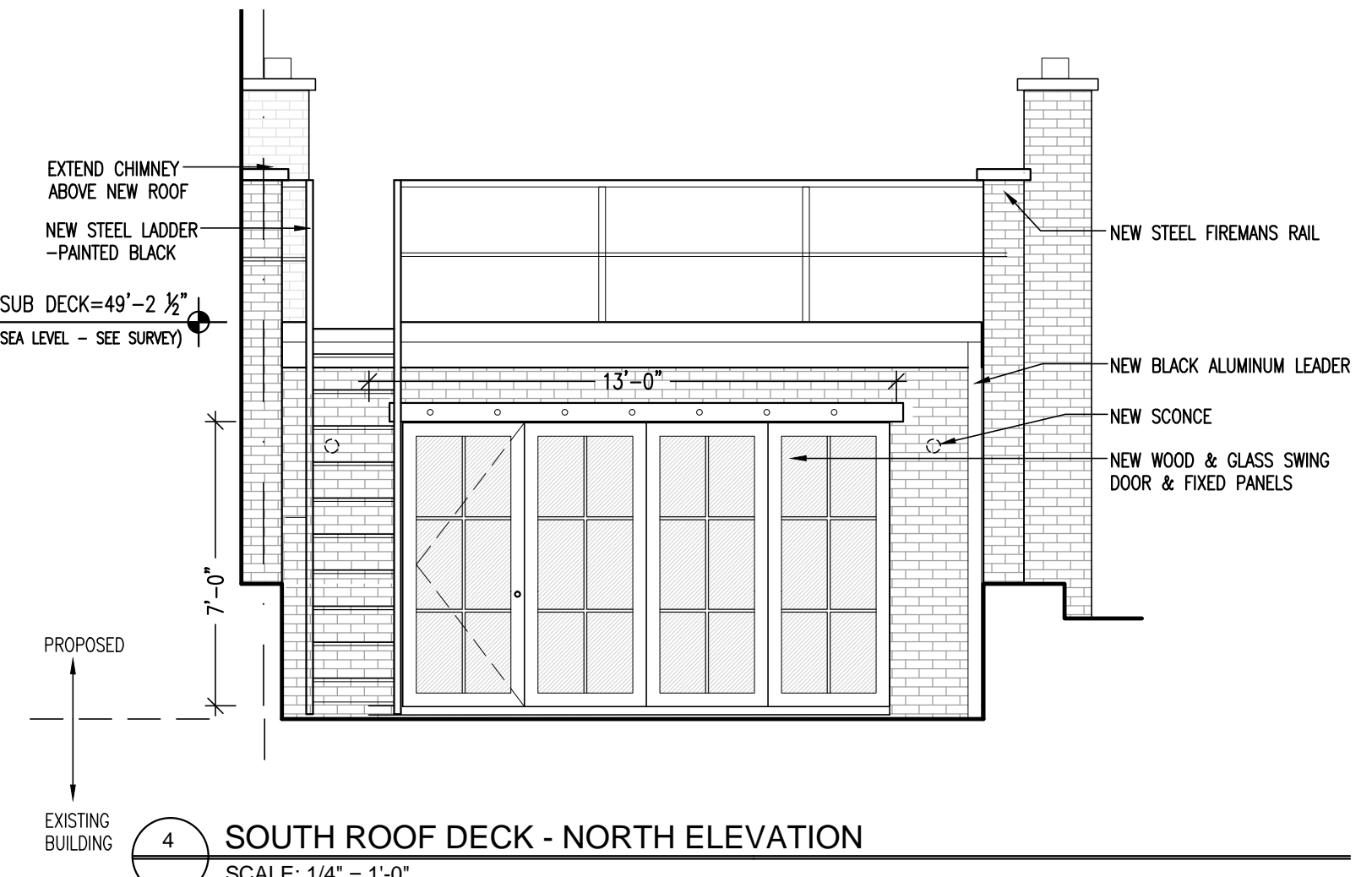

4 SOUTH ROOF DECK - NORTH ELEVATION
SCALE: 1/4" = 1'-0"



2 EXISTING REAR ELEVATION
SCALE: 1/4" = 1'-0"

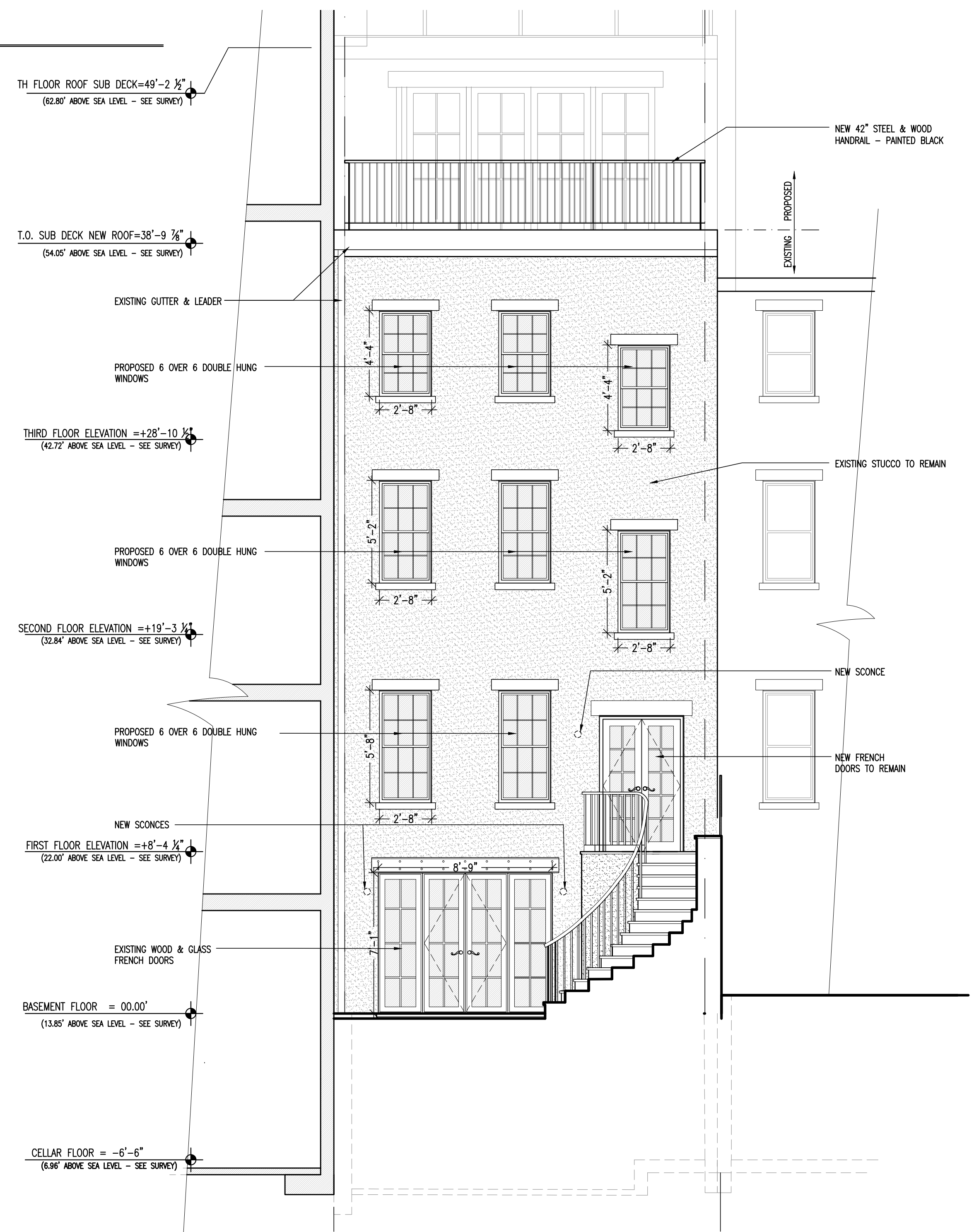

2 PROPOSED REAR ELEVATION
SCALE: 1/4" = 1'-0"

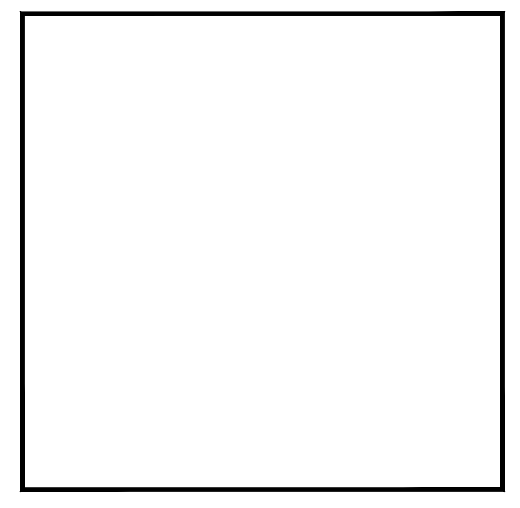

BAXT INGUI
Architects PC

20 Vesey Street Suite 900
New York, New York 10007
T. 212.233.6740 F. 212.962.5126
© 2011

28 FEB 2017
TO LPC

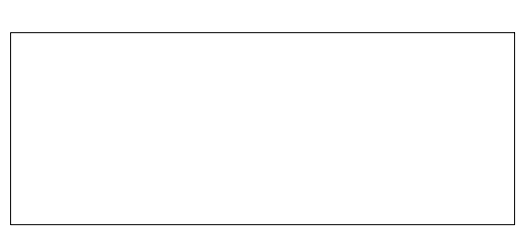
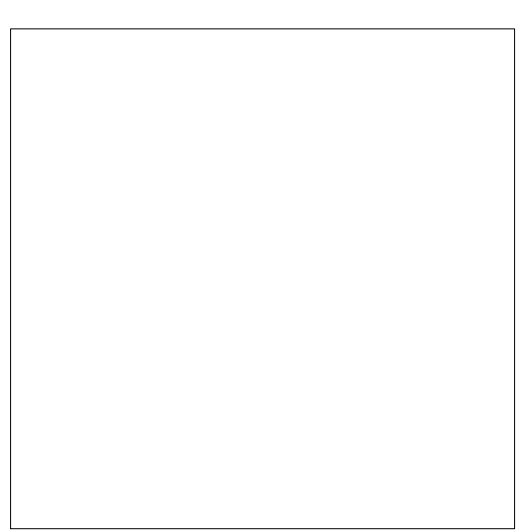

**Connolly
Residence**
97 BARROW ST
NEW YORK, NY

A-201.00
EXISTING & PROPOSED
REAR ELEVATION
7 OF 12

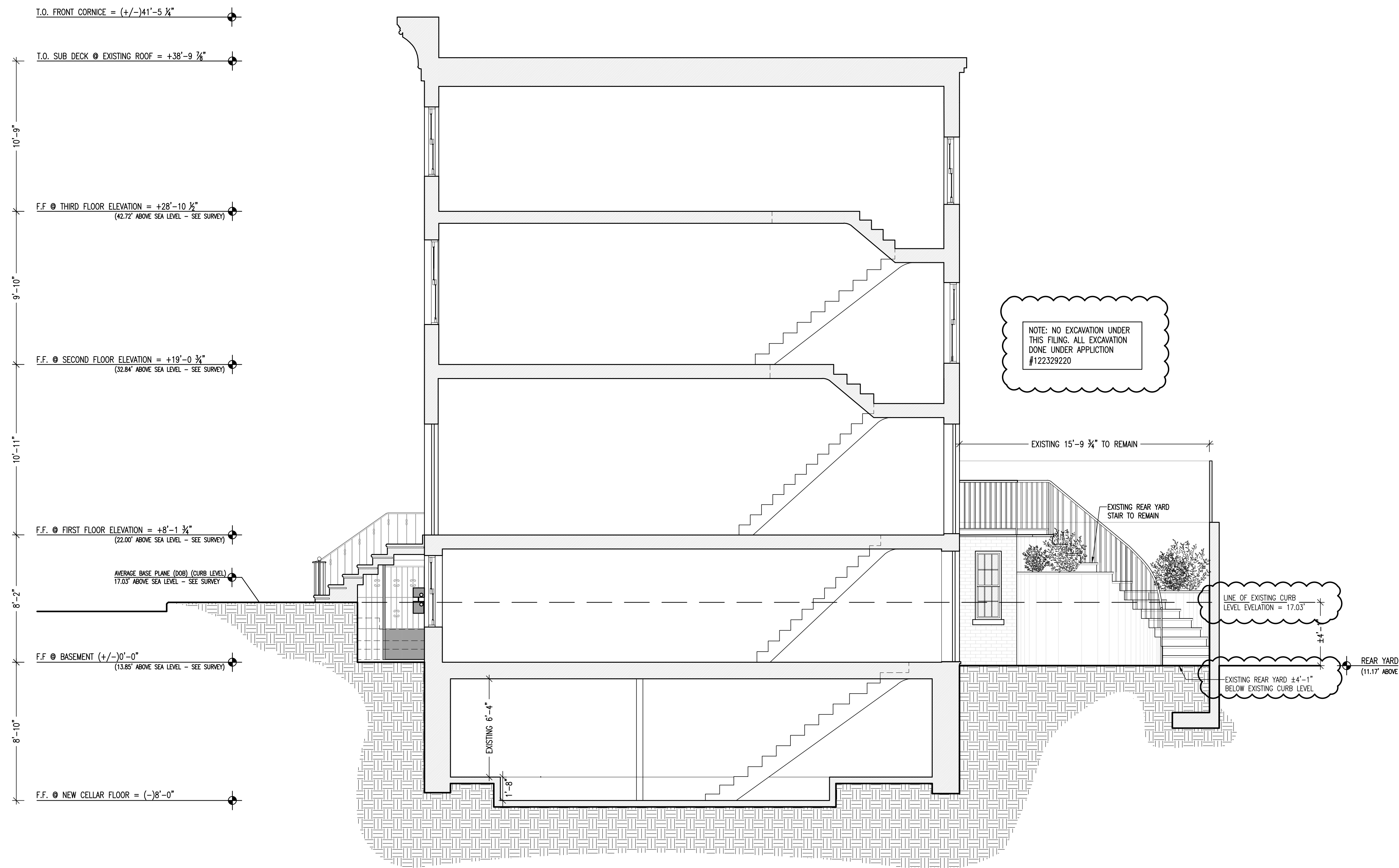

EXISTING SECTION
SCALE: 1/4" = 1'-0"

28 FEB 2017
TO LPC

**Connolly
Residence**

97 BARROW ST
NEW YORK, NY

A-300.00

EXISTING SECTION

28 FEB 2017
TO LPC

**Connolly
Residence**
97 BARROW ST
NEW YORK, NY

A-301.00

PROPOSED SECTION

9 OF 12

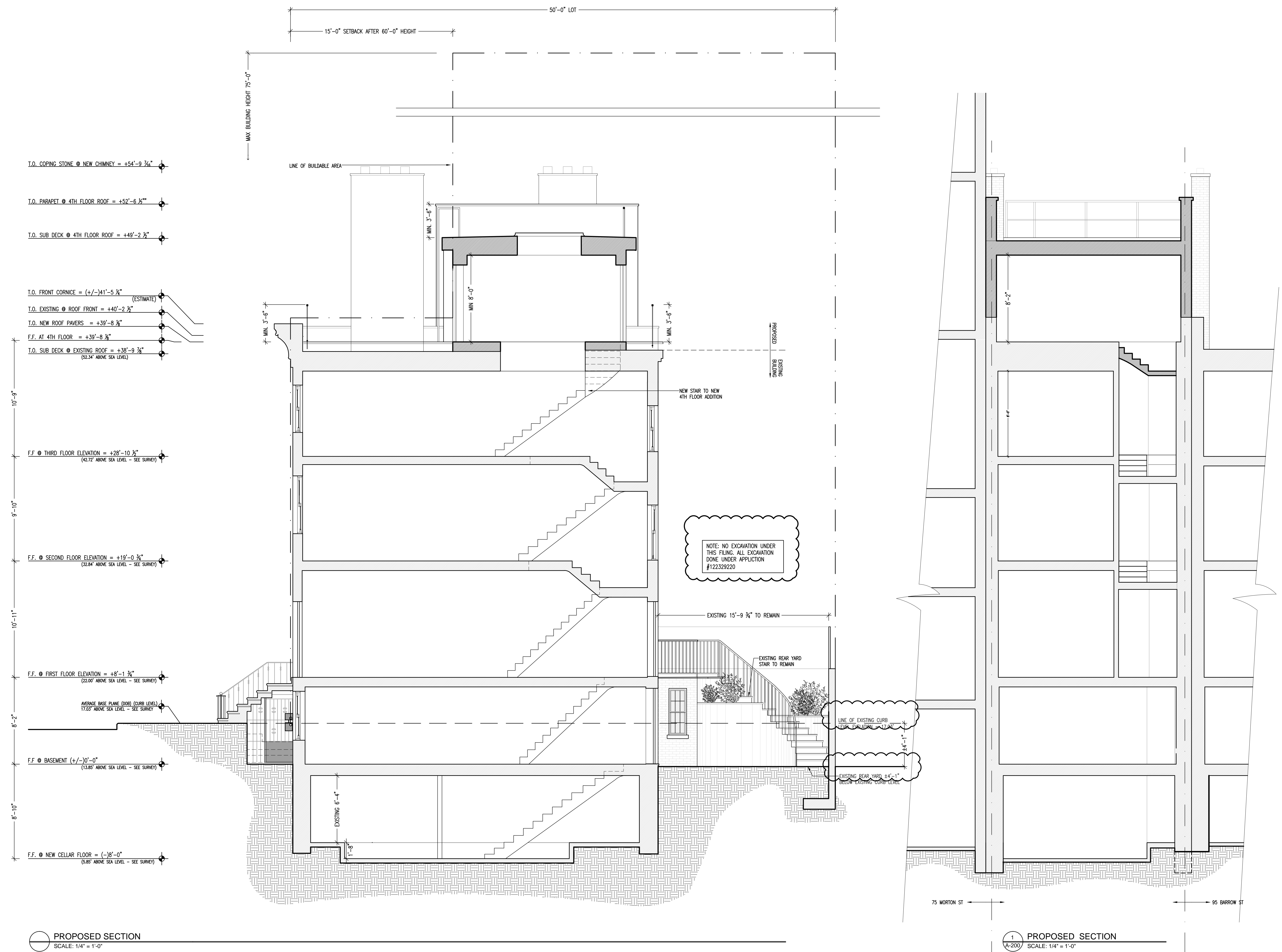

T.O. COPING STONE @ NEW CHIMNEY = +54'-9 3/4"

T.O. PARAPET @ 4TH FLOOR ROOF = +52'-6 1/2"

T.O. SUB DECK @ 4TH FLOOR ROOF = +49'-2 1/2"

T.O. FRONT CORNICE = (+/-)41'-5 1/4" (ESTIMATE)

T.O. EXISTING @ ROOF FRONT = +40'-2 1/2"

T.O. NEW ROOF PAVERS = +39'-8 1/4"

F.F. AT 4TH FLOOR = +39'-8 1/4"

T.O. SUB DECK @ EXISTING ROOF = +38'-9 3/4" (52.34' ABOVE SEA LEVEL)

F.F. @ THIRD FLOOR ELEVATION = +28'-10 1/2" (42.72' ABOVE SEA LEVEL - SEE SURVEY)

F.F. @ SECOND FLOOR ELEVATION = +19'-0 3/4" (32.84' ABOVE SEA LEVEL - SEE SURVEY)

F.F. @ FIRST FLOOR ELEVATION = +8'-1 3/4" (22.00' ABOVE SEA LEVEL - SEE SURVEY)

AVERAGE BASE PLANE (DOB) (CURB LEVEL) 17.03' ABOVE SEA LEVEL - SEE SURVEY

F.F. @ BASEMENT (+/-)0'-0" (13.85' ABOVE SEA LEVEL - SEE SURVEY)

F.F. @ NEW CELLAR FLOOR = (-)8'-0" (5.85' ABOVE SEA LEVEL - SEE SURVEY)

NOTE: NO EXCAVATION UNDER THIS FILING. ALL EXCAVATION DONE UNDER APPLICATION #122329220

LINE OF EXISTING CURB LEVEL ELEVATION = 17.03'

EXISTING REAR YARD ±4'-1" BELOW EXISTING CURB LEVEL

PROPOSED SECTION
SCALE: 1/4" = 1'-0"

1 **PROPOSED SECTION**
A-200 SCALE: 1/4" = 1'-0"

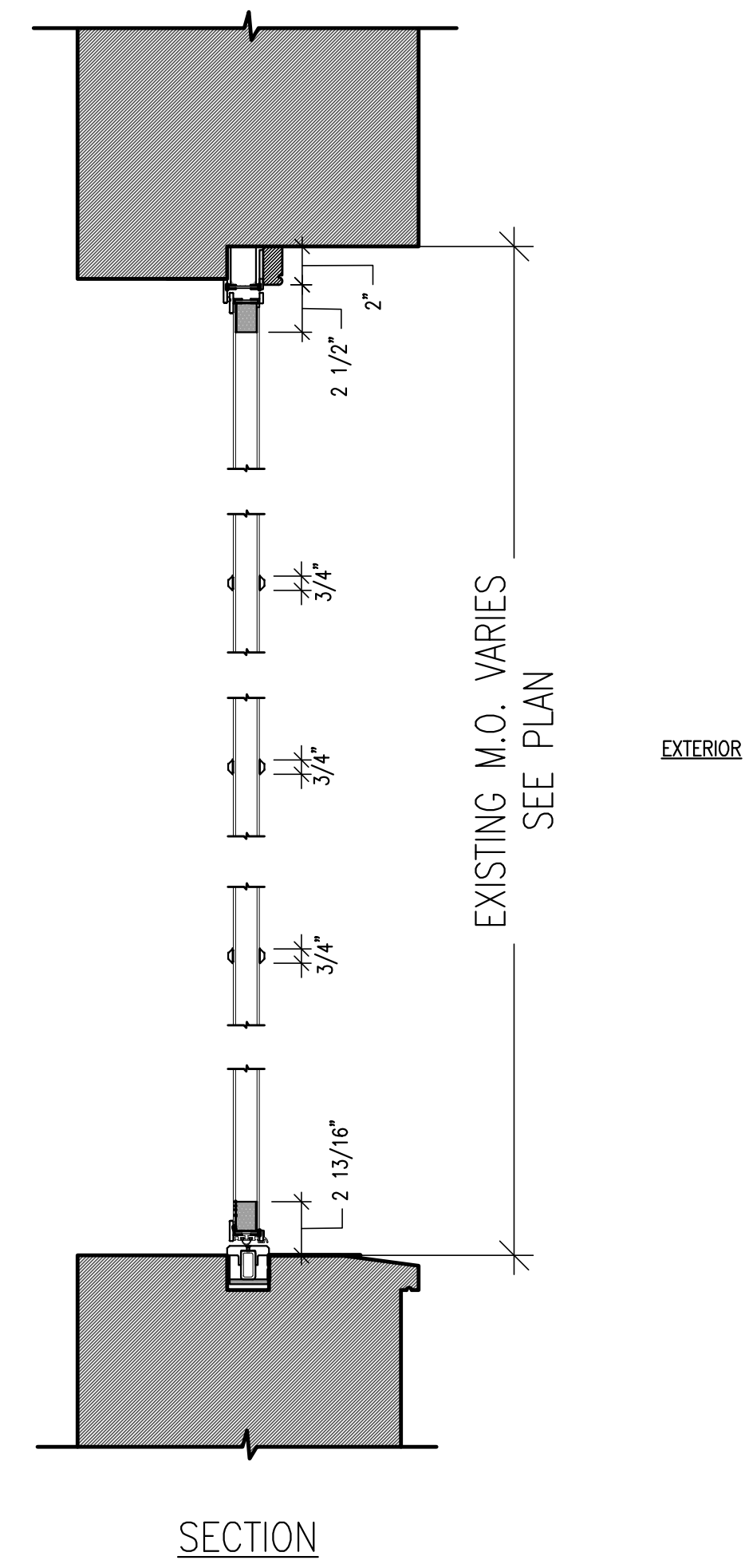

SECTION

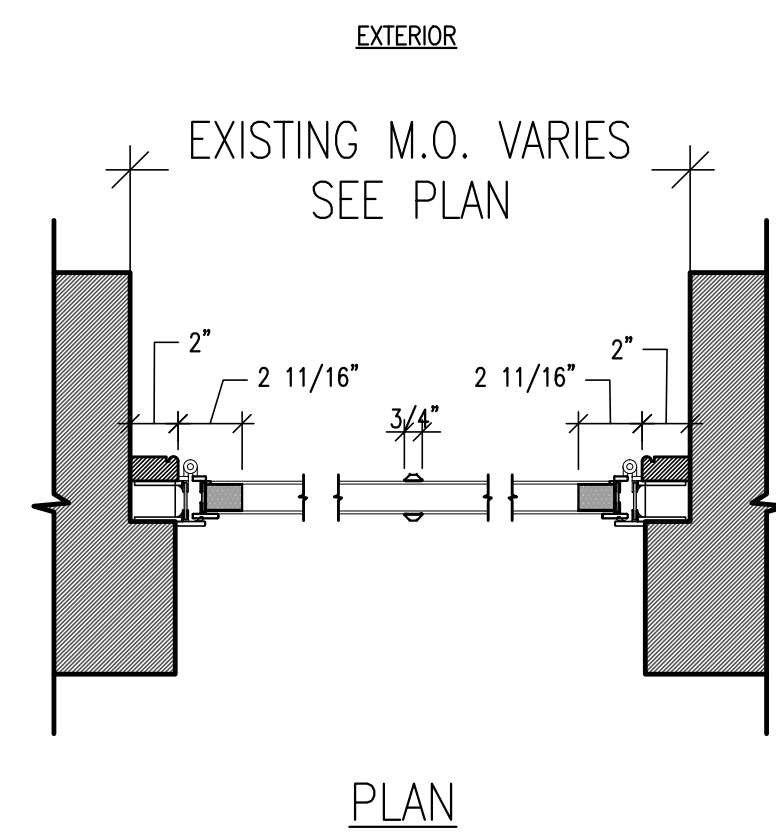

PLAN

2 STEEL & GLASS DOOR DETAIL
SCALE: 1-1/2" = 1'-0"

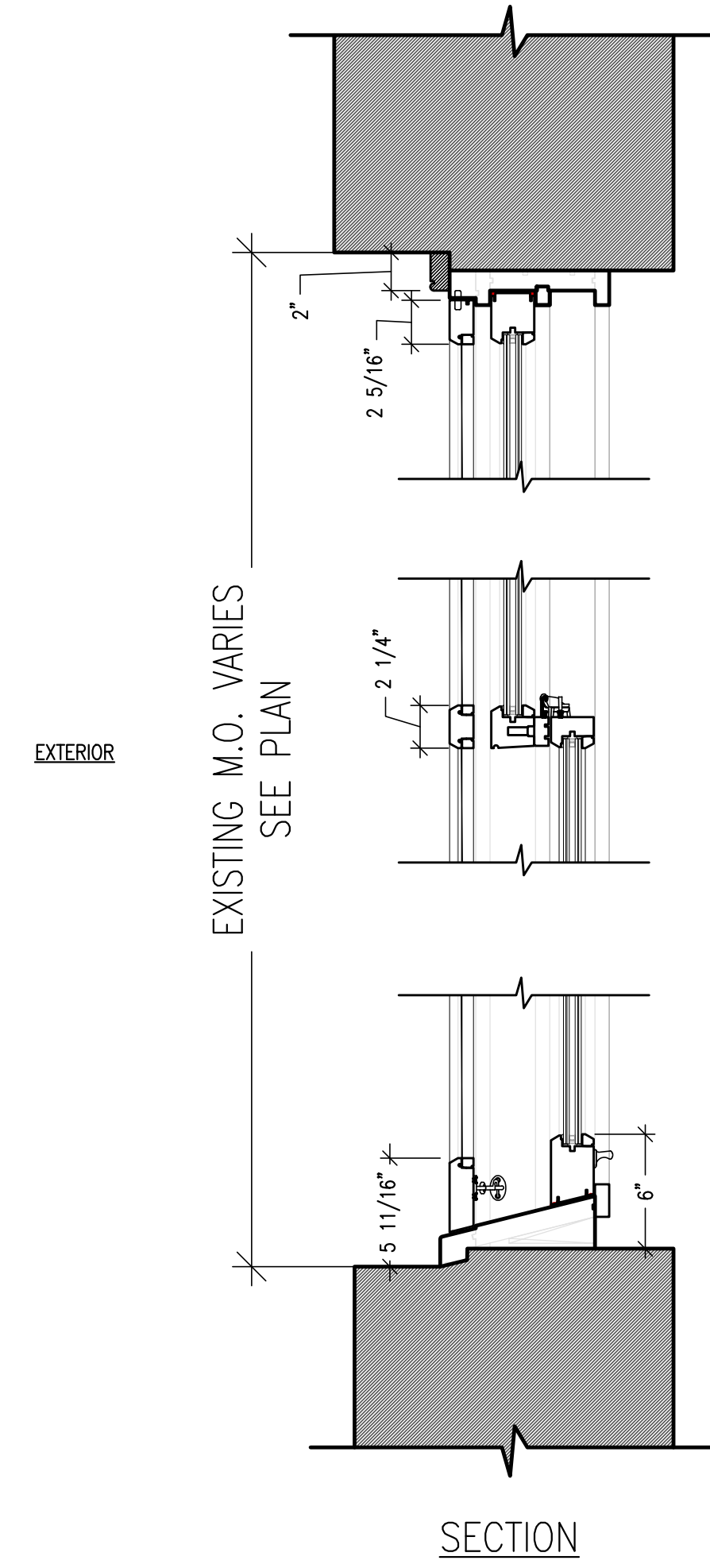

SECTION

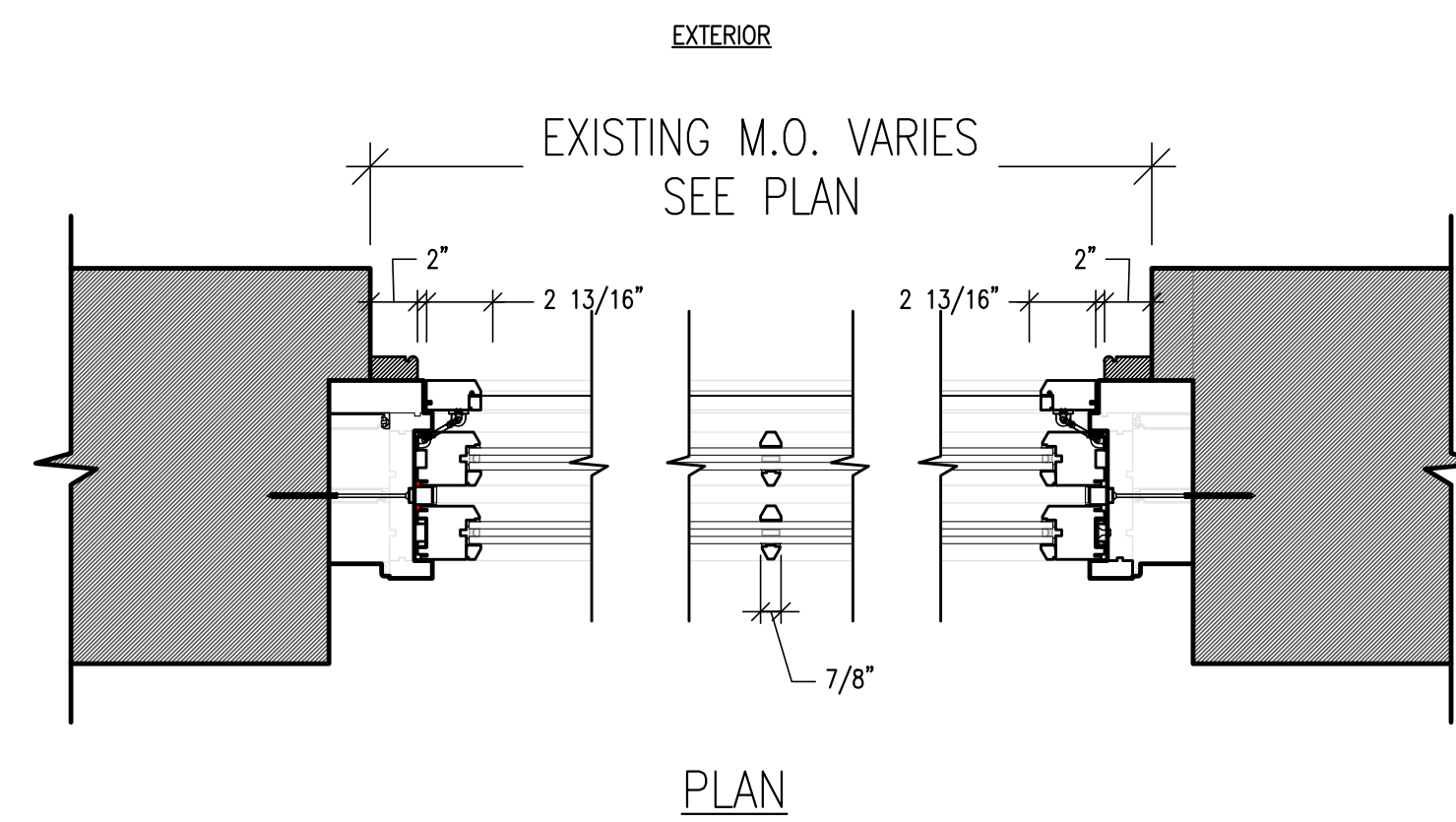

PLAN

2 REILEY DOUBLE HUNG WINDOW DETAILS
SCALE: 1-1/2" = 1'-0"

28 FEB 2017
TO LPC

**Connolly
Residence**

97 BARROW ST
NEW YORK, NY

A-500

FLOOR PLANS

12 OF 12

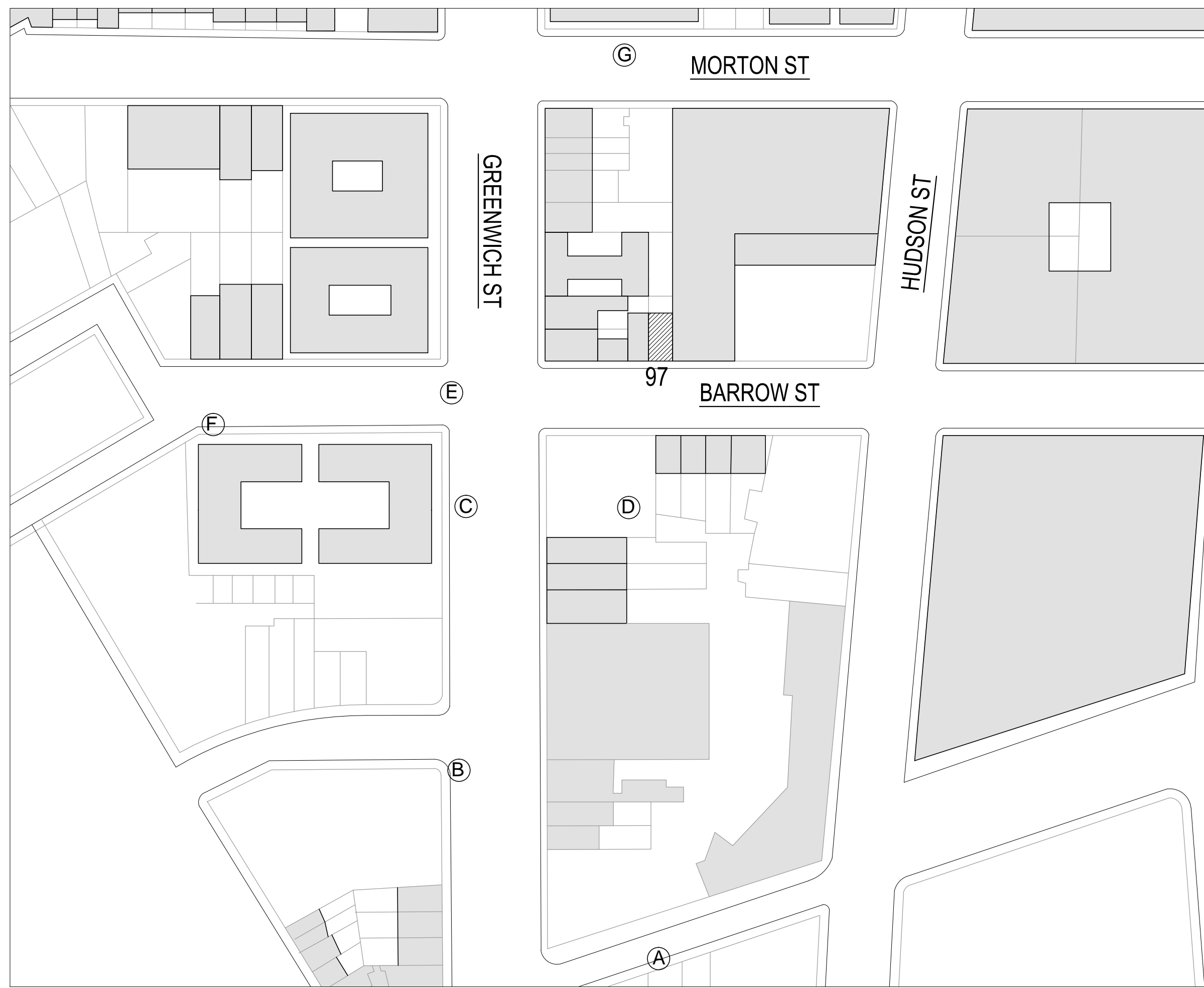

2 SIGHT LINE KEY PLAN
SCALE: NOT TO SCALE

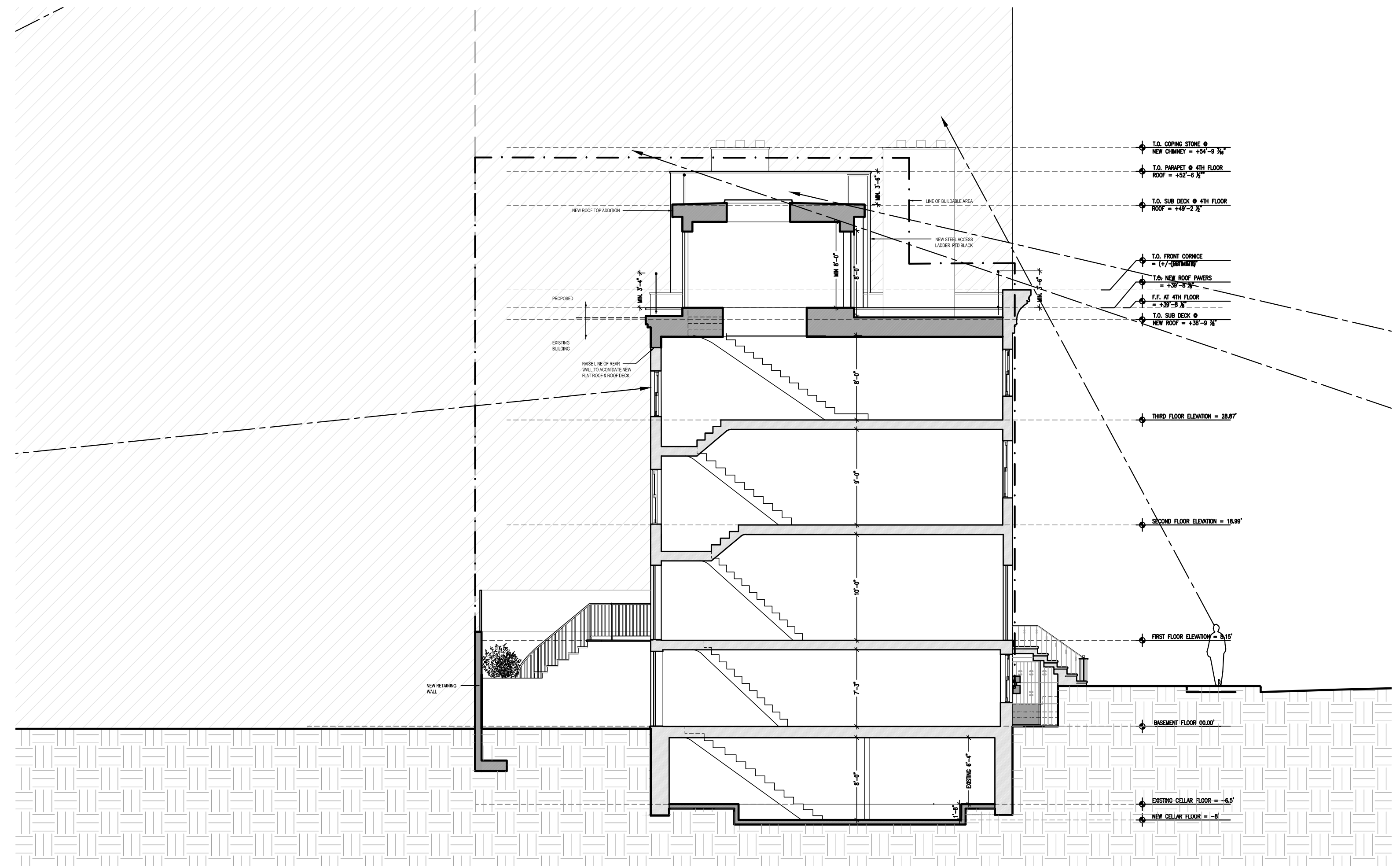

1 PROPOSED SECTION
SCALE: NOT TO SCALE

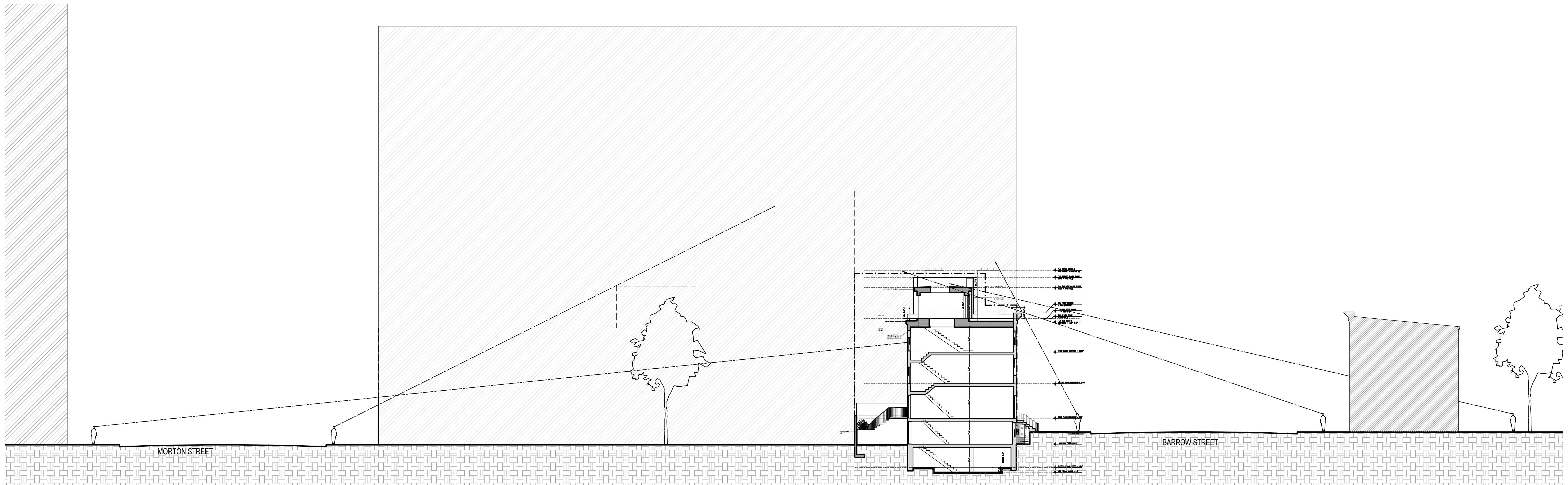

3 LINE OF SIGHT DIAGRAM
SCALE: NOT TO SCALE

BAXT INGUI
Architects PC

20 Vesey Street Suite 900
New York, New York 10007
T. 212.233.6740 F. 212.962.5126
© 2011

28 FEB 2017
TO LPC

Connolly
Residence

97 BARROW ST
NEW YORK, NY

LPC-01

LINE OF SIGHT
10 OF 12



A SIGHT LINE KEY PLAN
SCALE: NOT TO SCALE



1 SIGHT LINE LOCATION A
SCALE: NOT TO SCALE

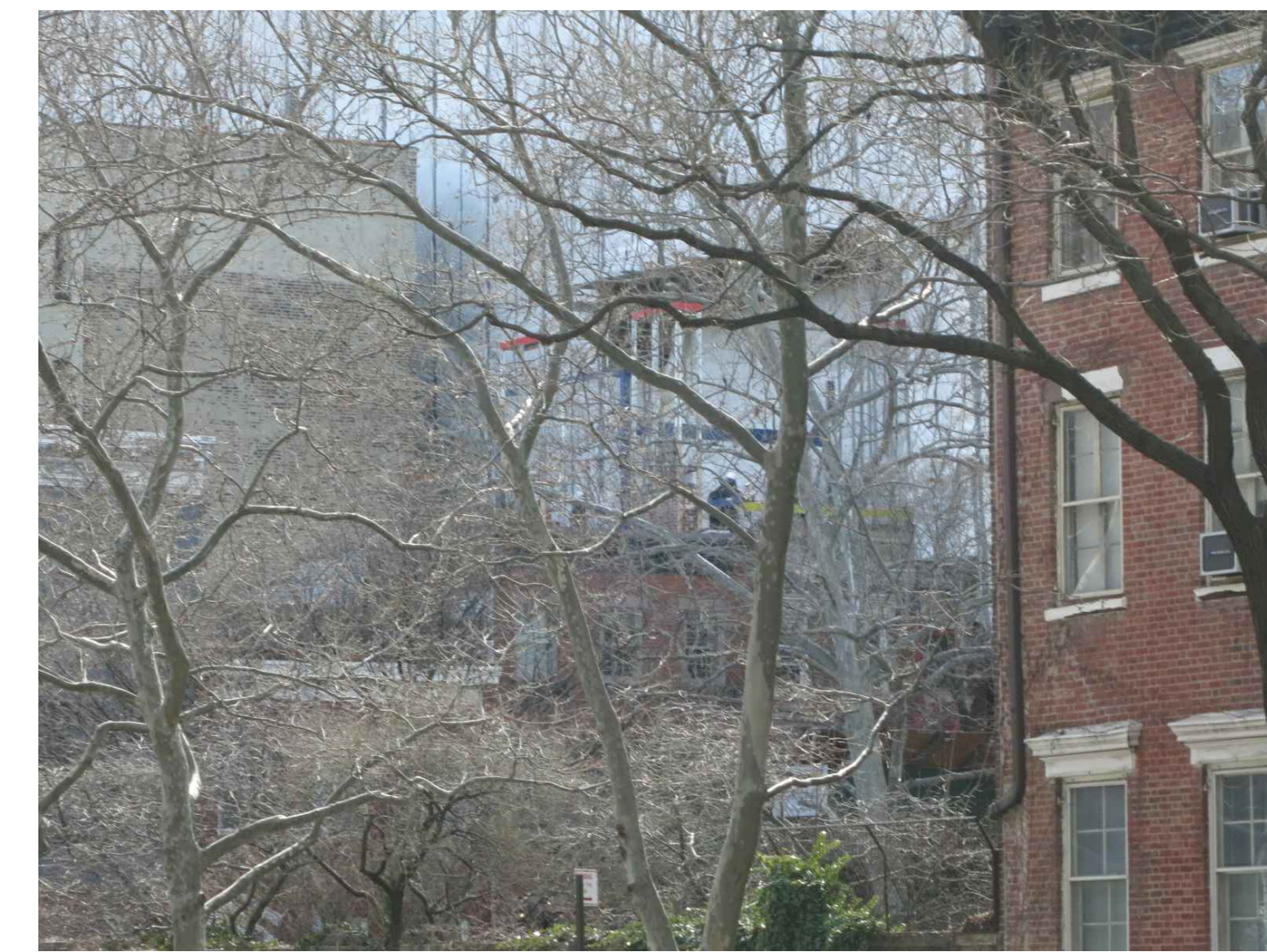

2 SIGHT LINE LOCATION B
SCALE: NOT TO SCALE

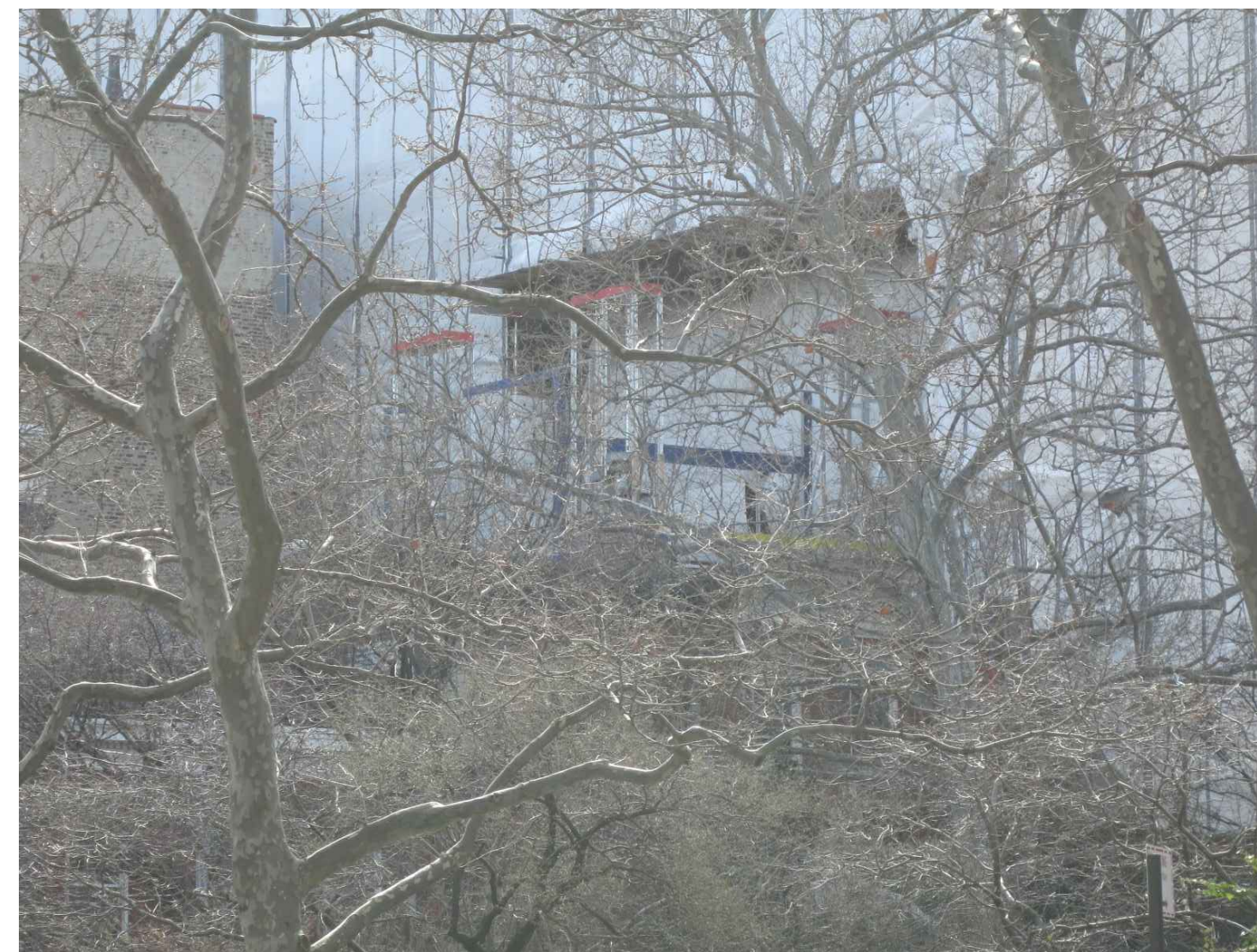

3 SIGHT LINE LOCATION C
SCALE: NOT TO SCALE

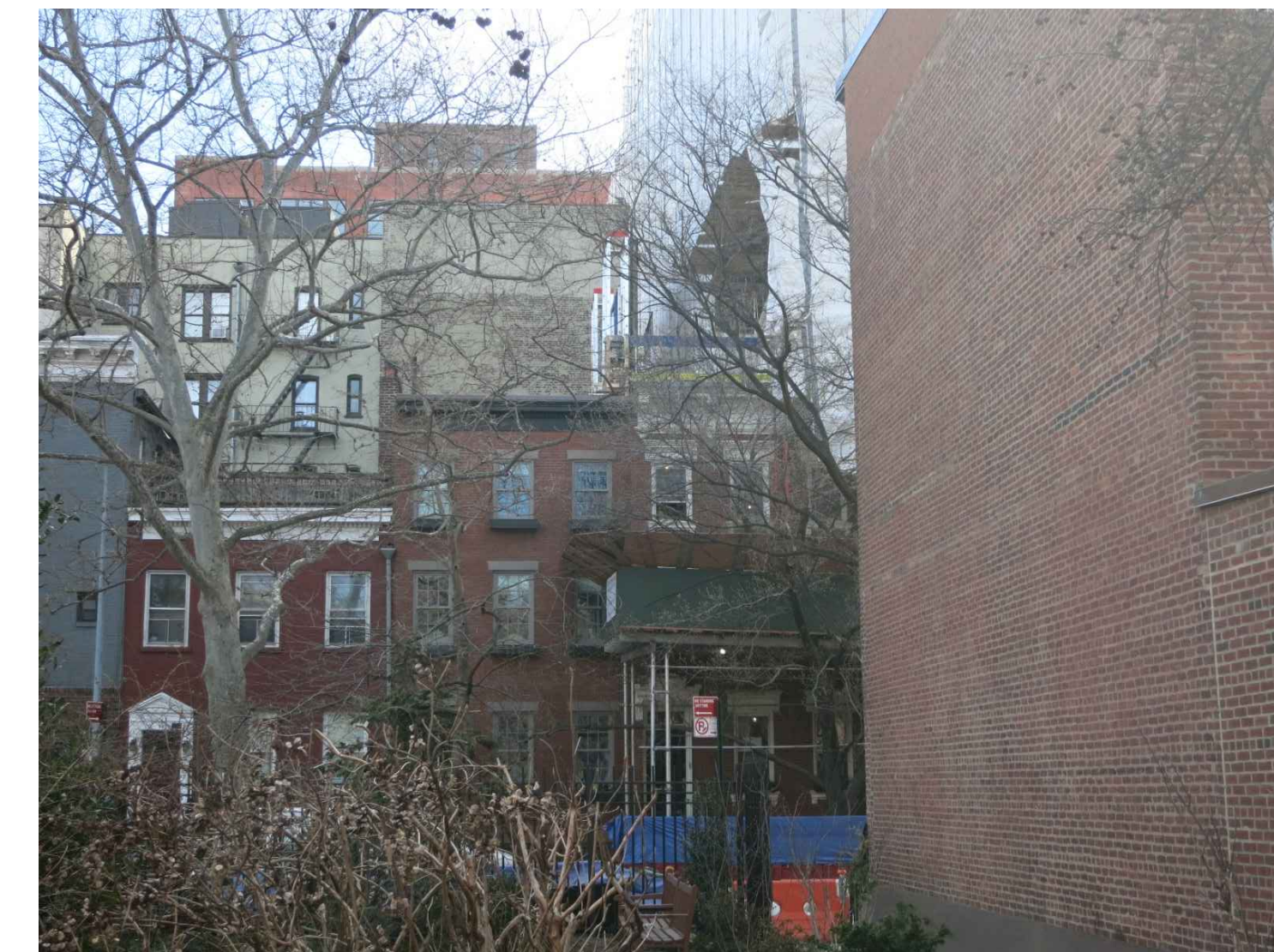

4 SIGHT LINE LOCATION D
SCALE: NOT TO SCALE

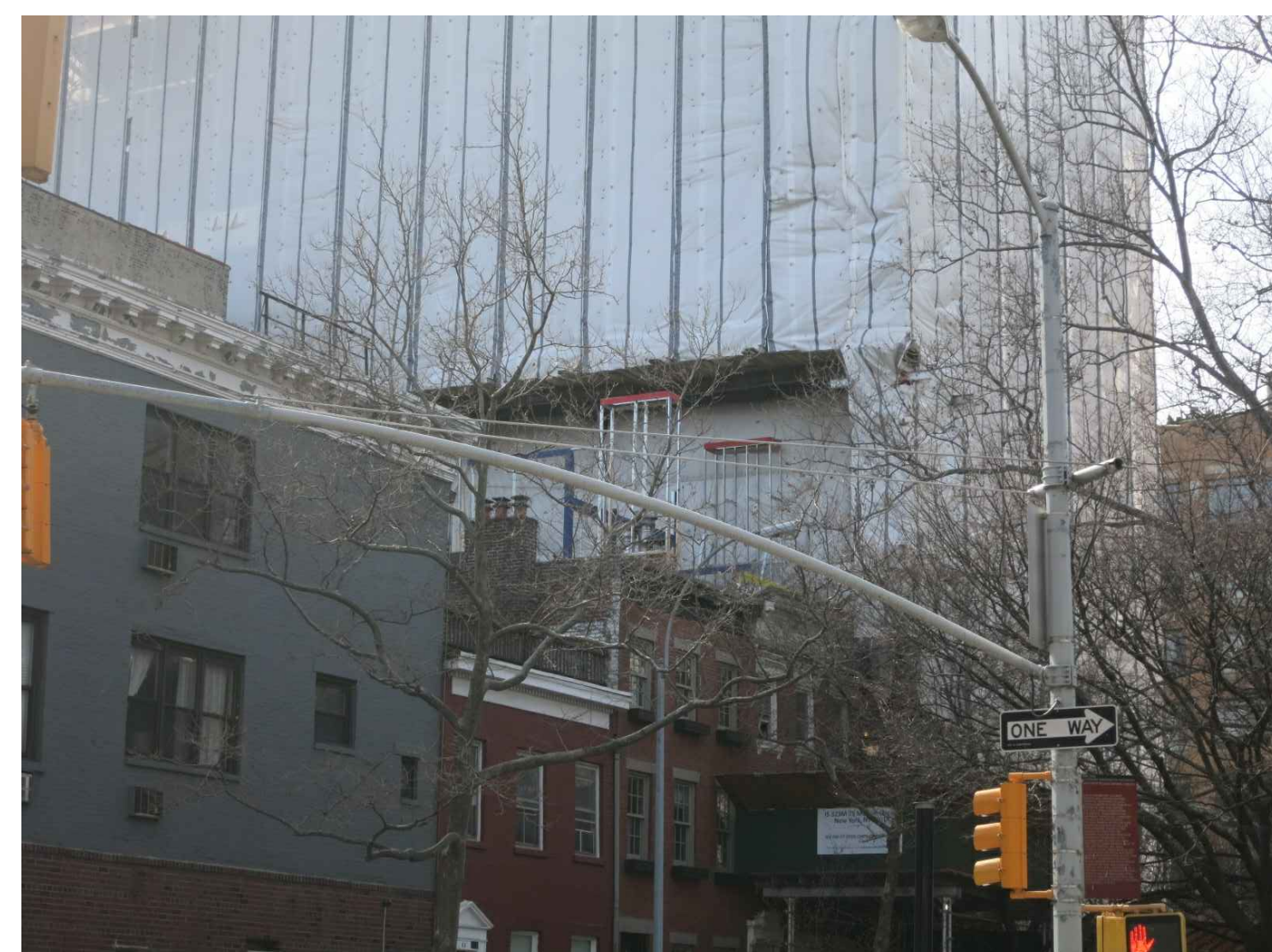

5 SIGHT LINE LOCATION E
SCALE: NOT TO SCALE

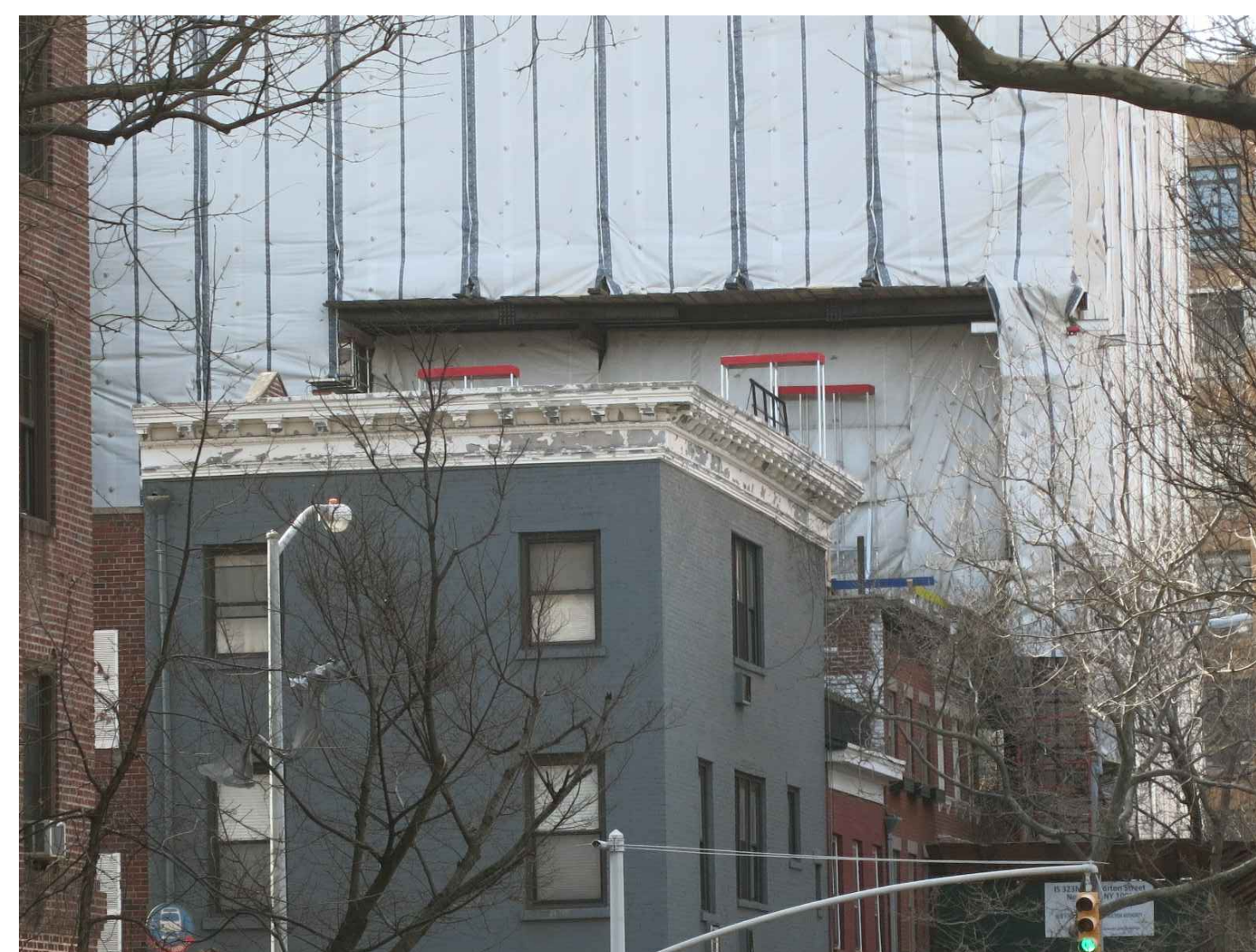

6 SIGHT LINE LOCATION F
SCALE: NOT TO SCALE



7 SIGHT LINE LOCATION G
SCALE: NOT TO SCALE

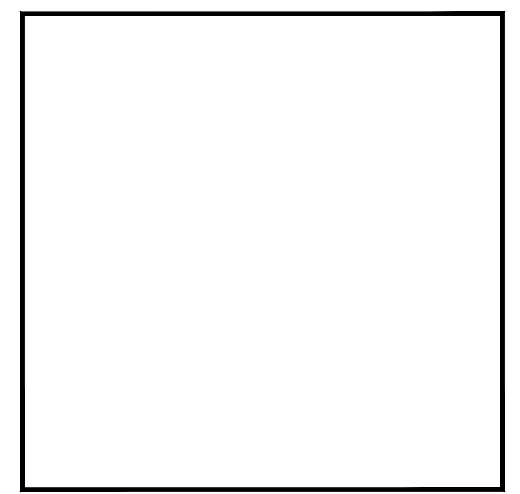

BAXTINGUI
Architects PC

20 Vesey Street Suite 900
New York, New York 10007
T. 212.233.6740 F. 212.962.5126
© 2011



28 FEB 2017
TO LPC

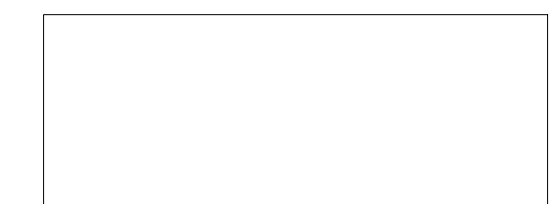
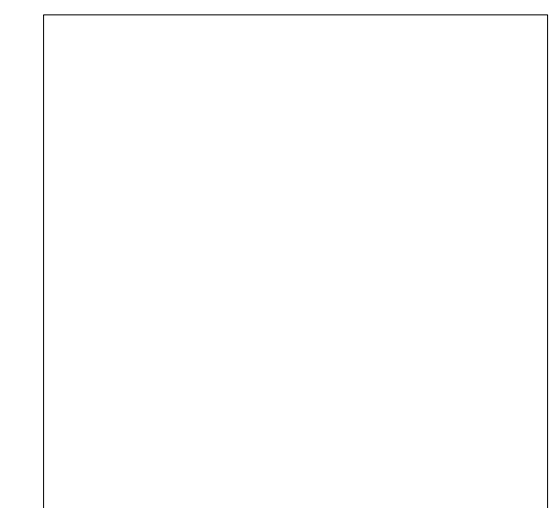

**Connolly
Residence**

97 BARROW ST
NEW YORK, NY

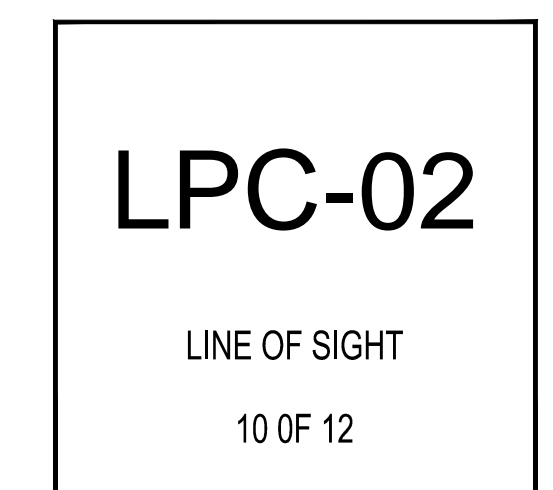

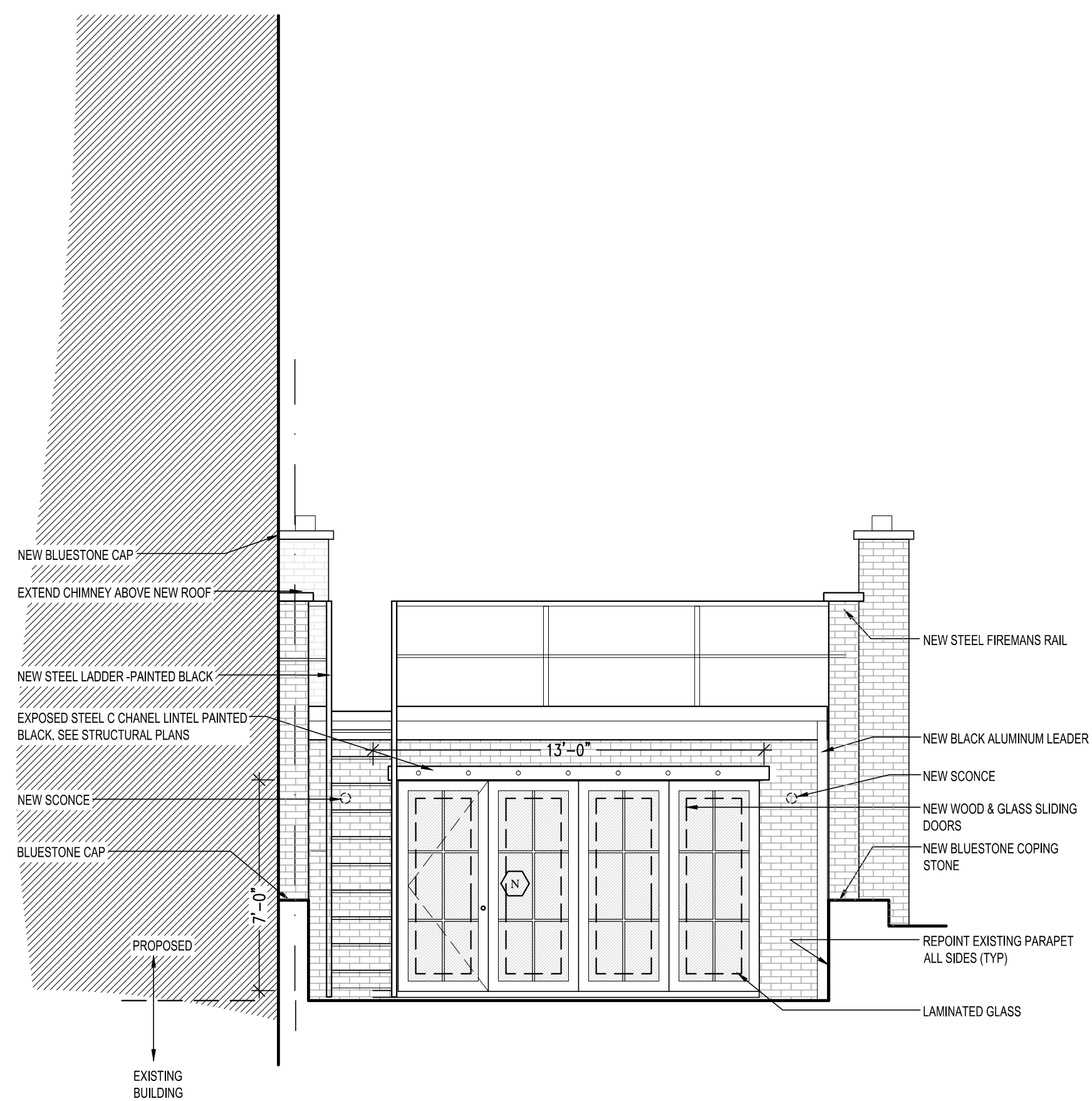

SOUTH ROOF DECK - NORTH ELEVATION
SCALE: NOT TO SCALE

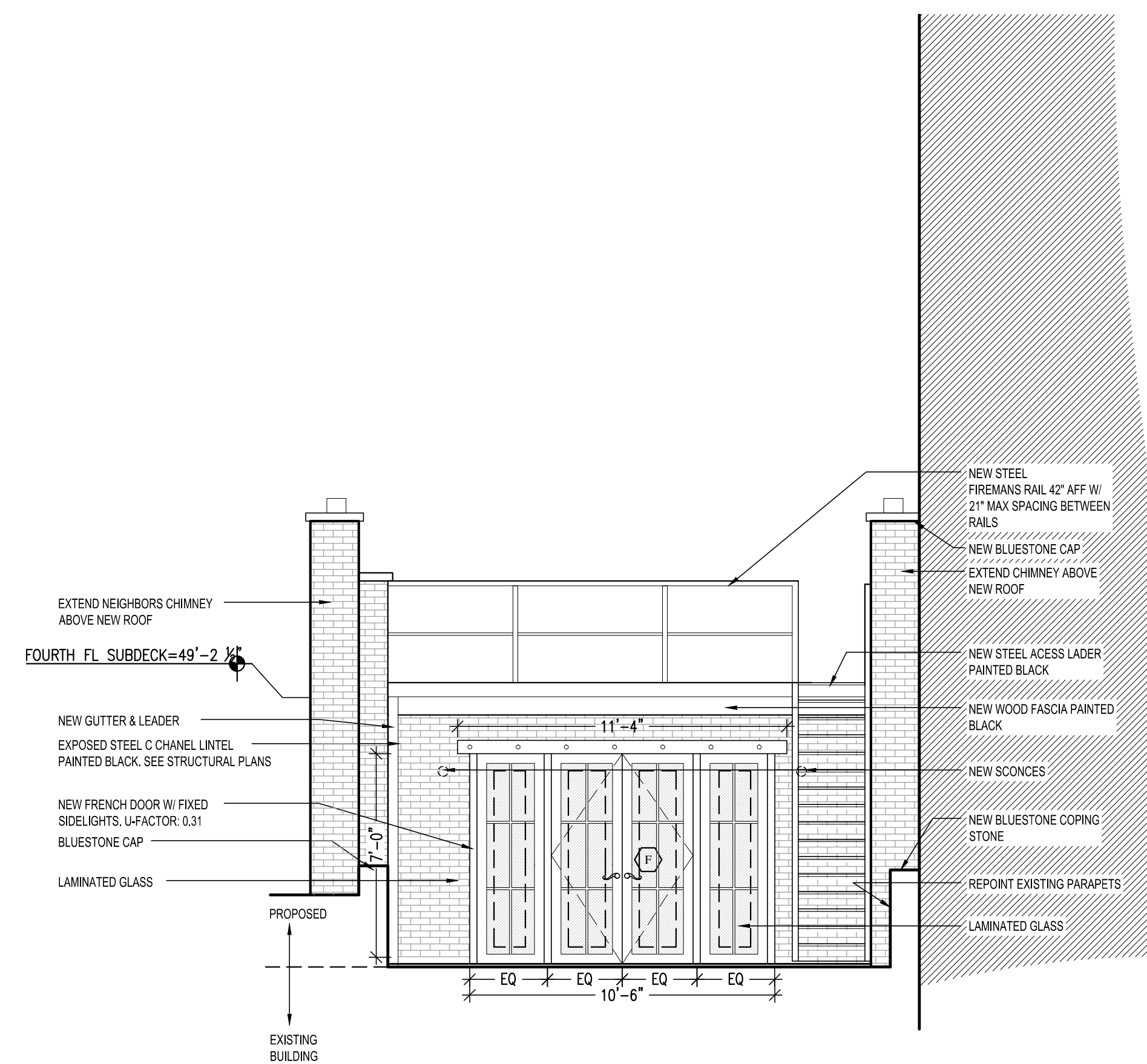

NORTH ROOF DECK - SOUTH ELEVATION
SCALE: 1/4" = 1'-0"

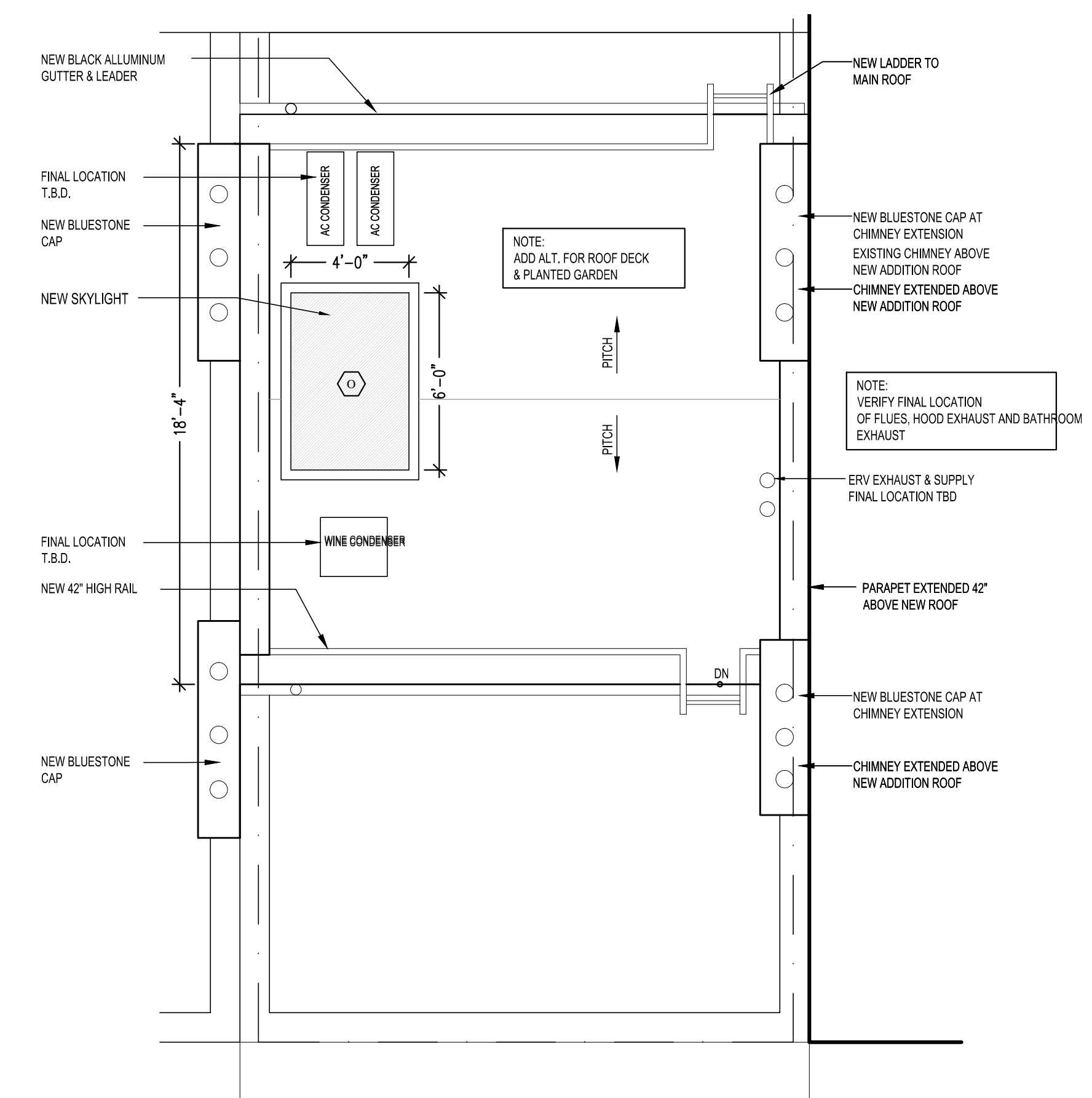

ROOF PLAN
SCALE: 1/4" = 1'-0"

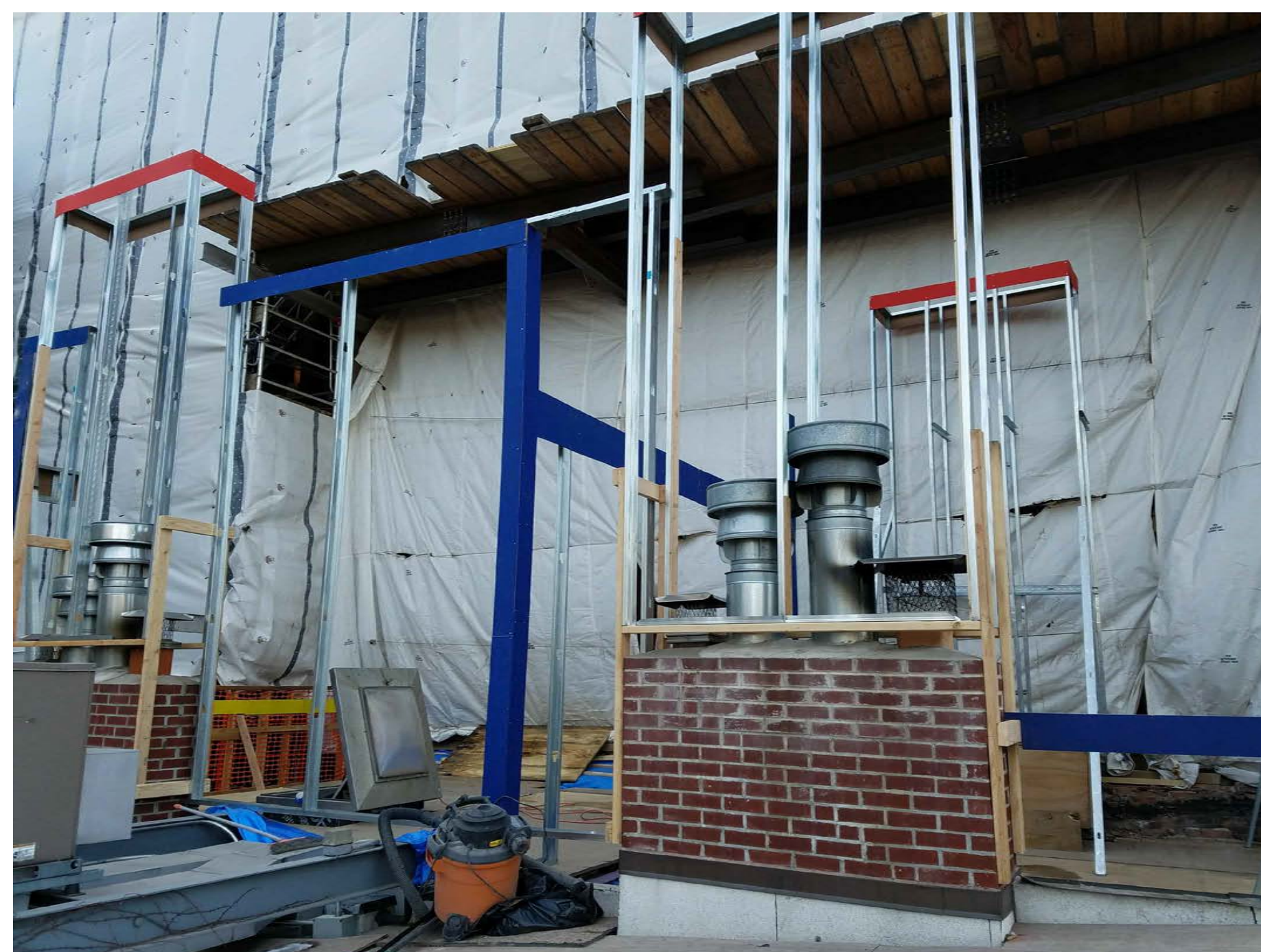

1 MOCK UP PHOTO
SCALE: NOT TO SCALE

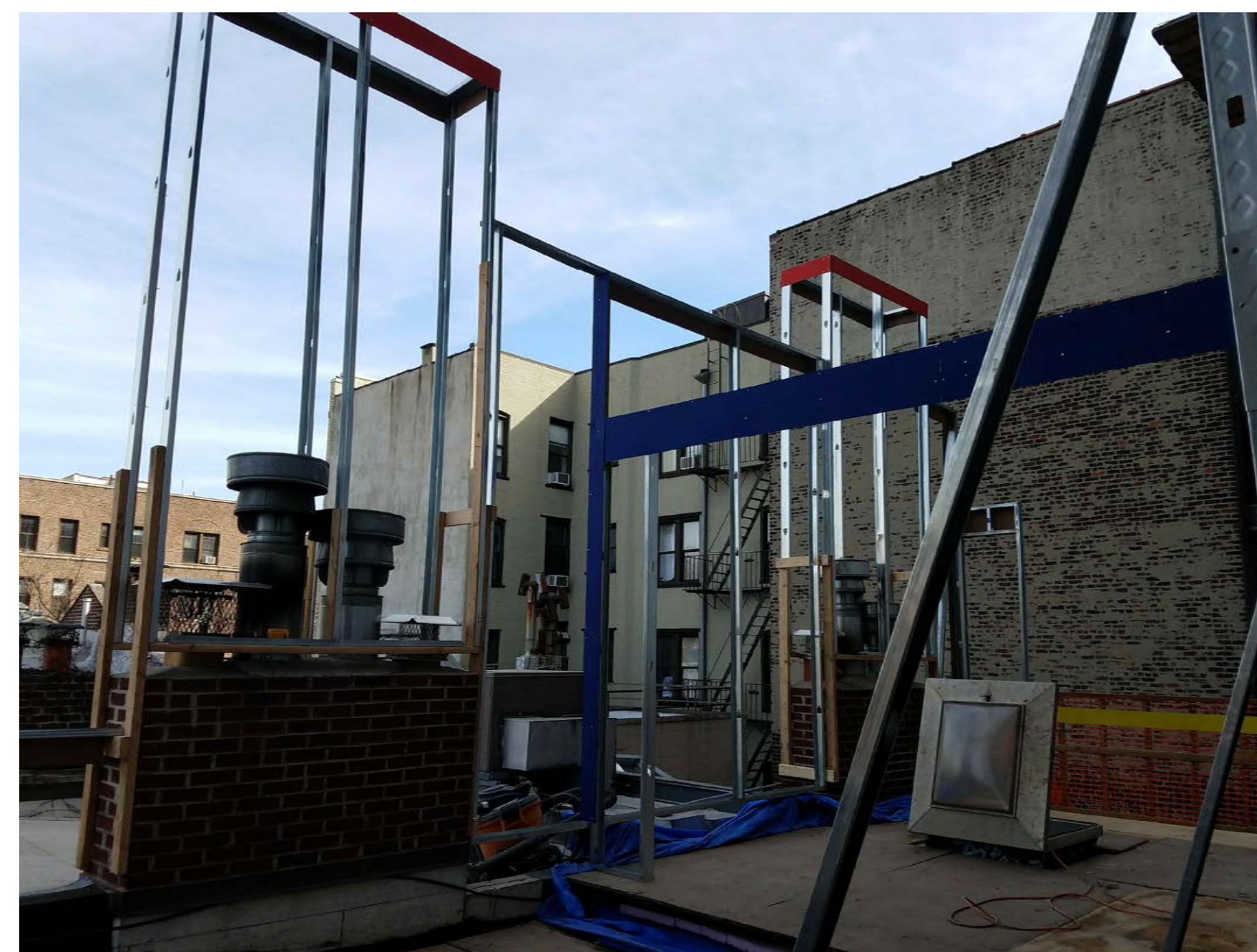

2 MOCK UP PHOTO
SCALE: NOT TO SCALE



3 MOCK UP PHOTO
SCALE: NOT TO SCALE



1 EXISTING FRONT FACADE
SCALE: 1-1/2" = 1'-0"

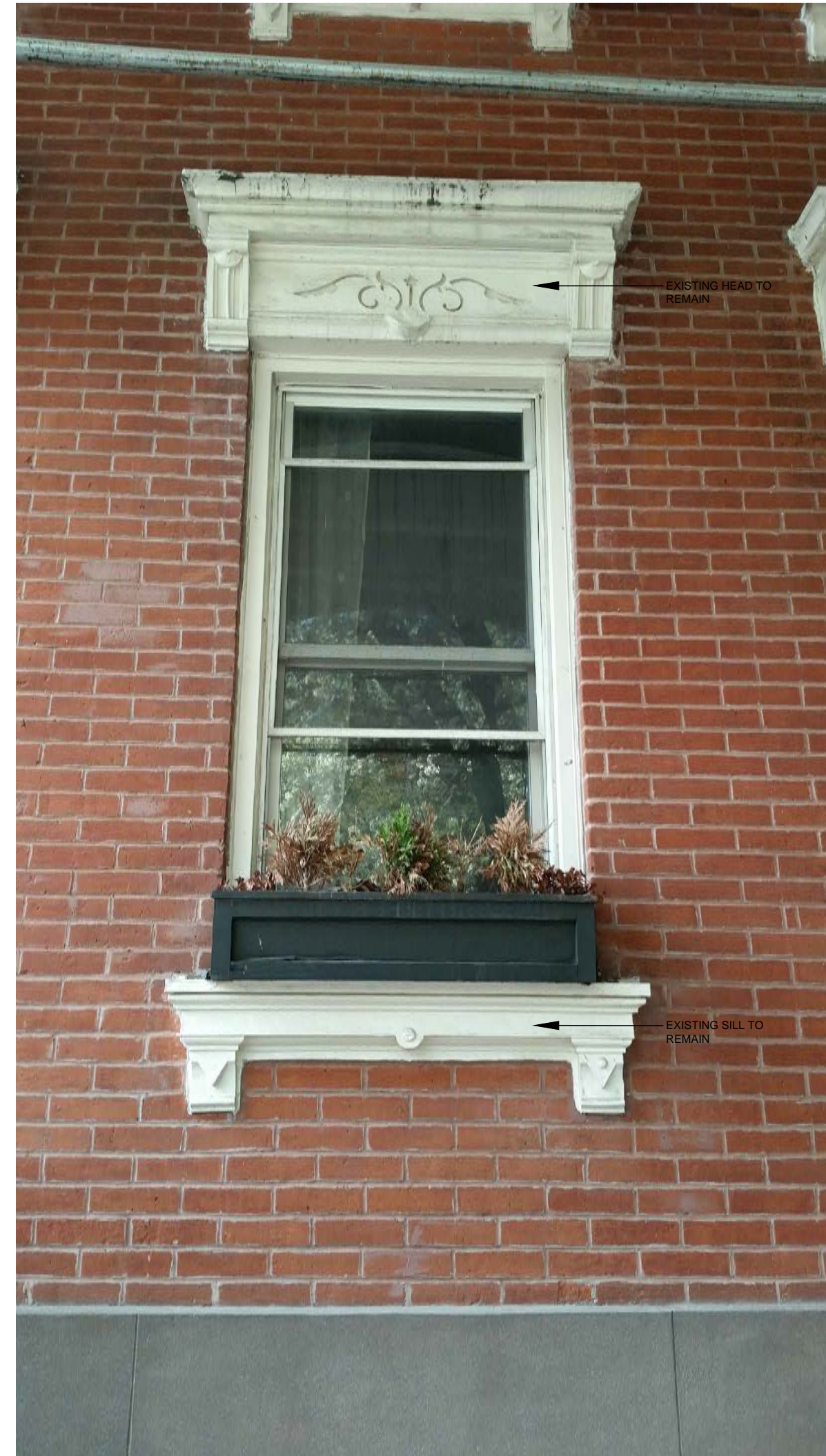

2 EXISTING FRONT FACADE
SCALE: 1-1/2" = 1'-0"

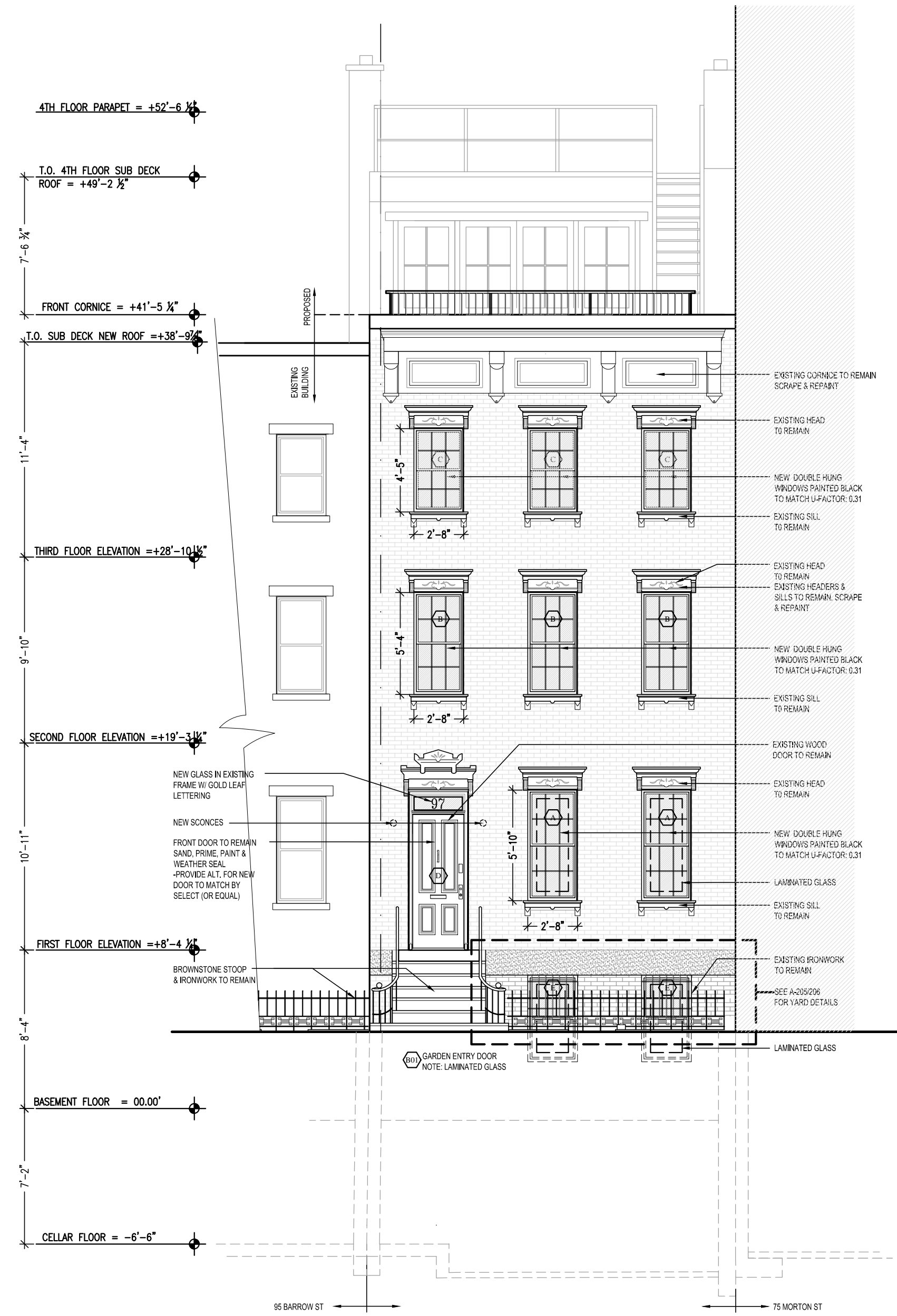

3 PROPOSED FRONT ELEVATION
SCALE: 1-1/2" = 1'-0"



4 EXISTING FRONT FACADE
SCALE: 1-1/2" = 1'-0"



5 90 - 94 BARROW STREET
SCALE: 1-1/2" = 1'-0"



6 95 BARROW STREET
SCALE: 1-1/2" = 1'-0"

28 FEB 2017
TO LPC

**Connolly
Residence**

97 BARROW ST
NEW YORK, NY

LPC-04

FACADE PHOTOS

1 OF 11